













A x 12  M6*20	B x 6  M6x40	C x 6  M6x45	D x 2  M6*55	E x 14  M6*22	F x 1 
G x 1 	H x 12 	I x 24 	J x 23 	L x 4  M6*22	M x 8 
N x 1 					

BHMA/STEP: 1





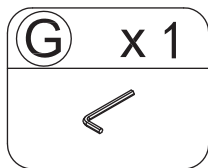
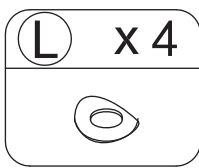
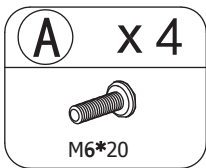
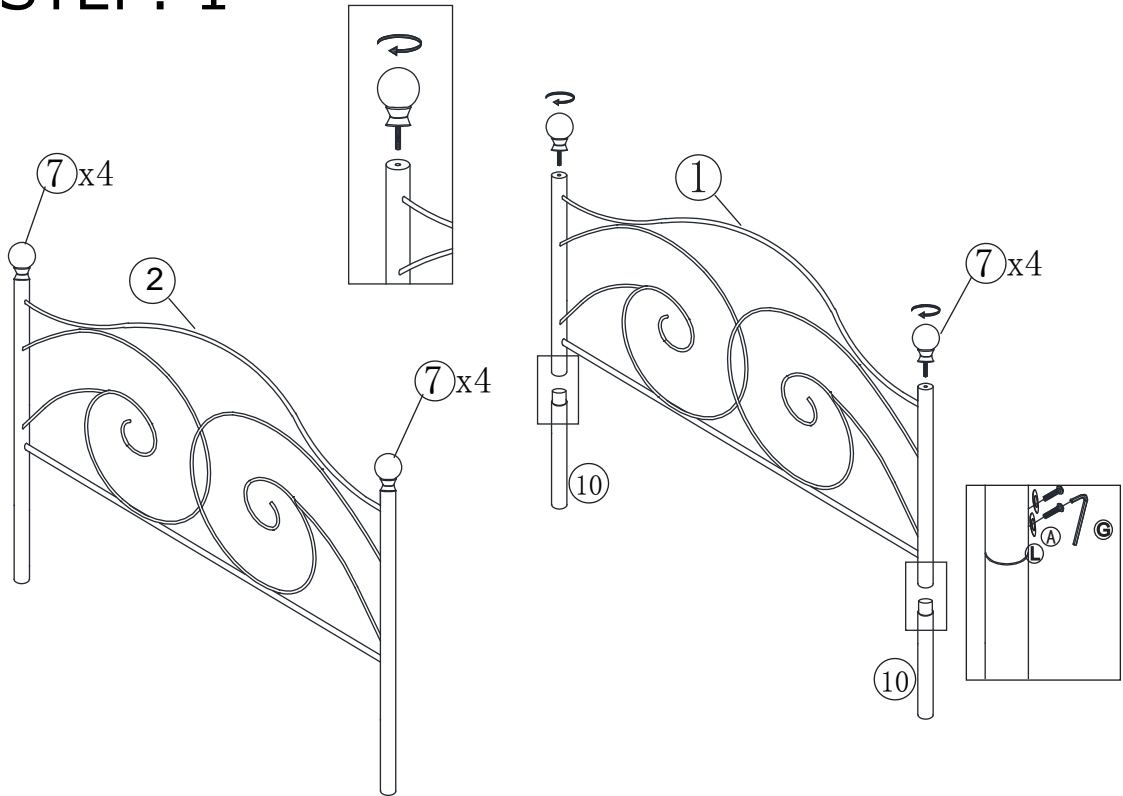
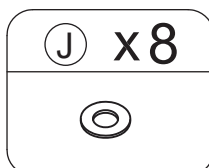
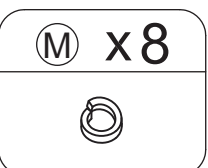
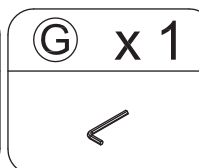
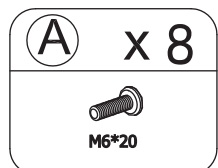
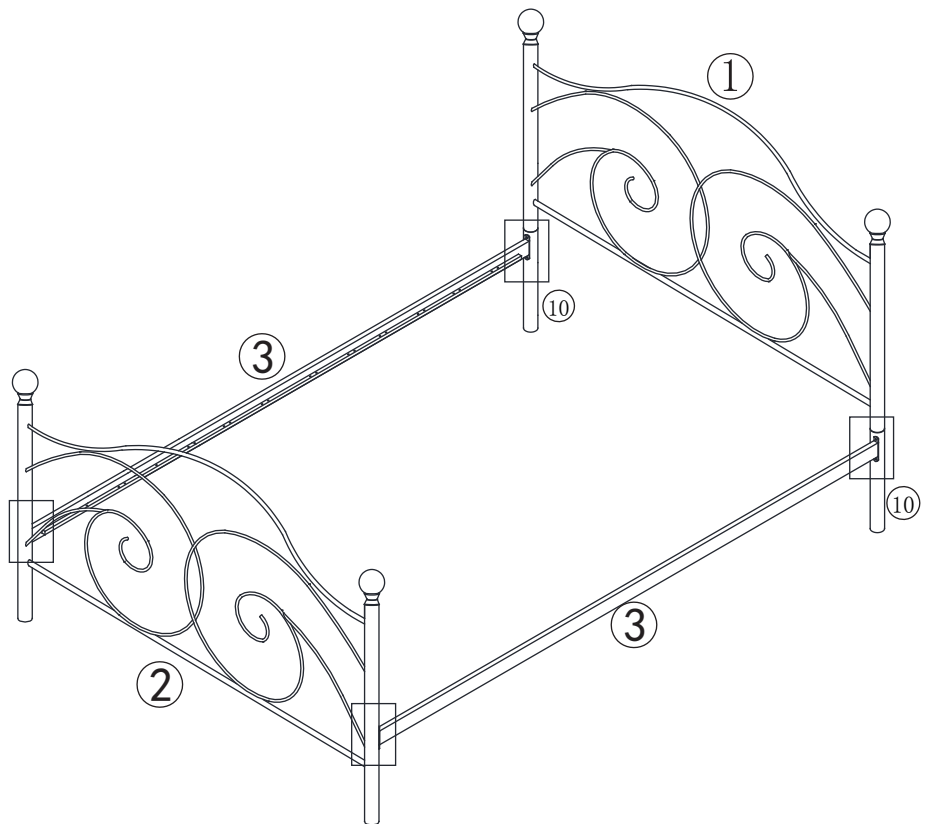
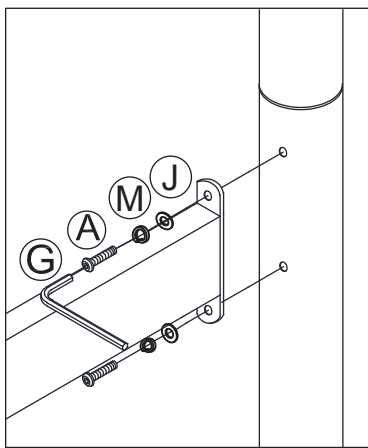

BHMA/STEP: 2

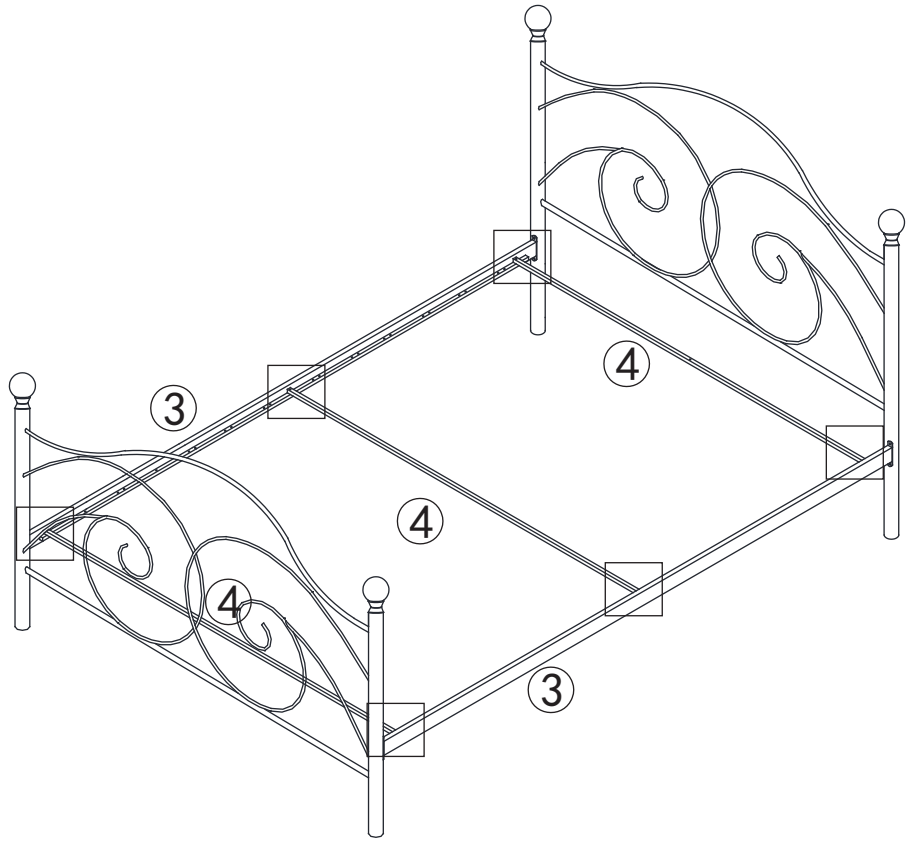
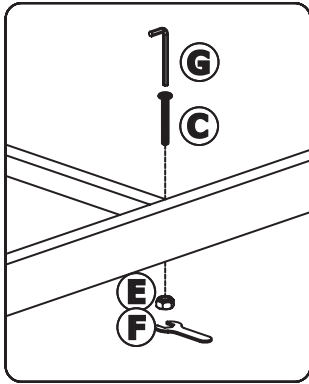







BHMA/STEP: 3

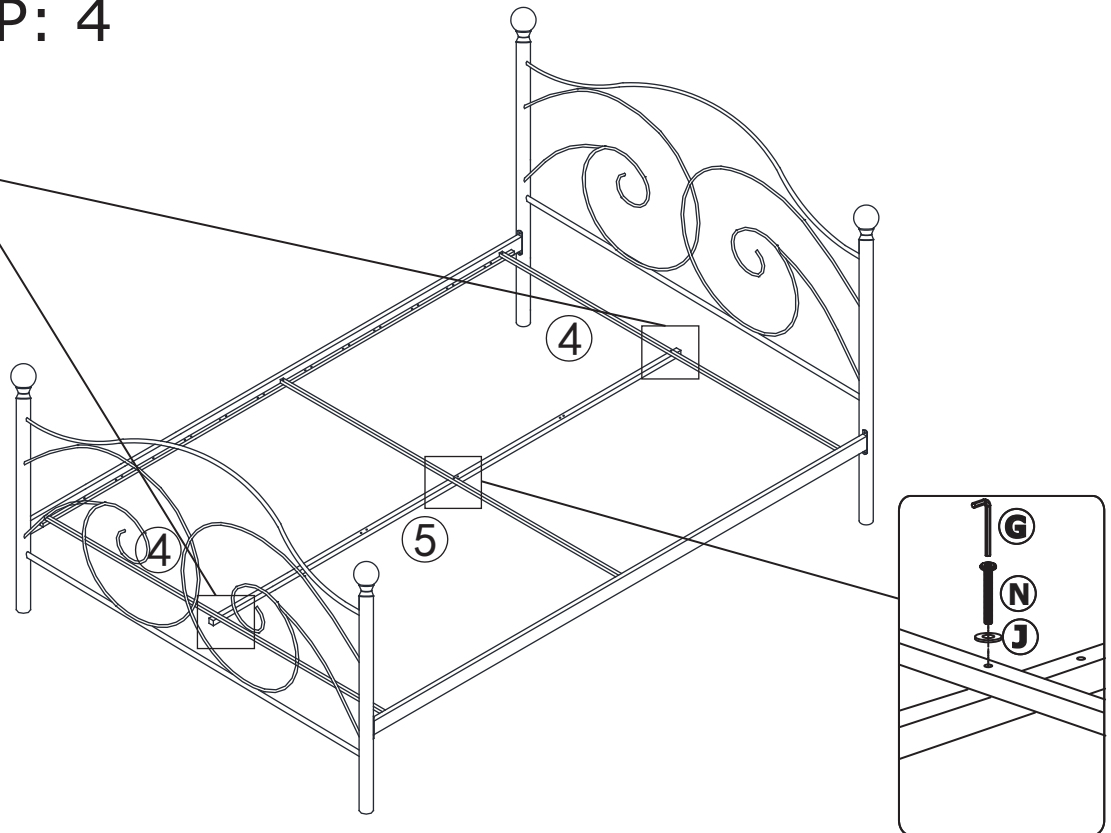
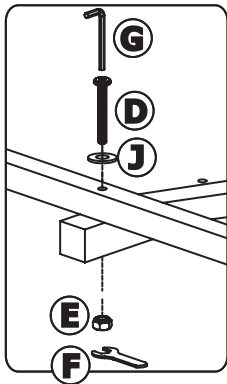

C X 6	E X 6	G X 1	F X 1
			
M6*45			

BHMA/STEP: 4



D X 2	J X 3	E X 2	G X 1	F X 1	N X 1
					
M6*55					M6*30

BHMA/STEP: 5

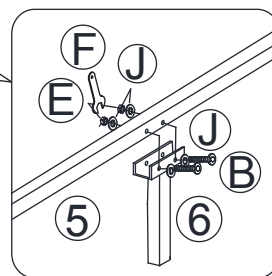
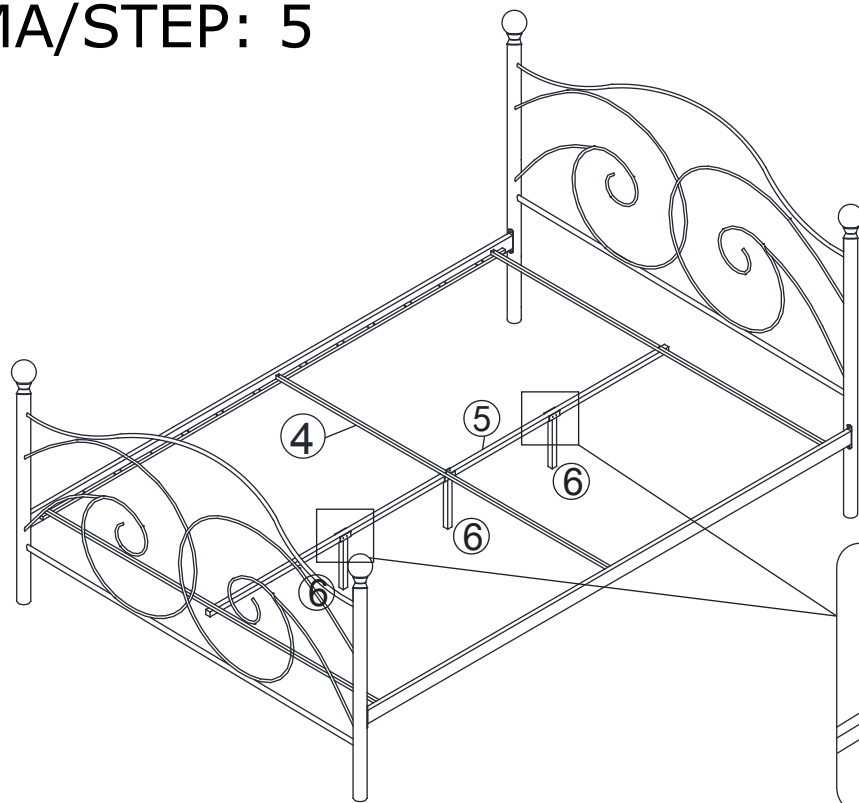

* ΒΛΕΠΕ
ΤΕΛΕΥΤΑΙΑ
ΣΕΛΙΔΑ /
CHECK LAST
PAGE

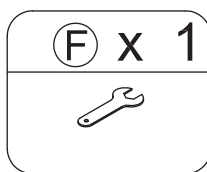
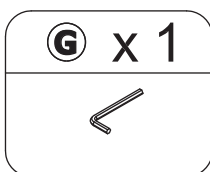
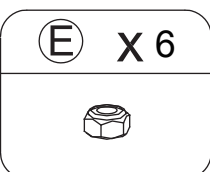
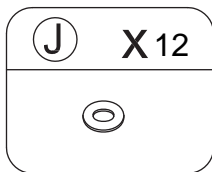
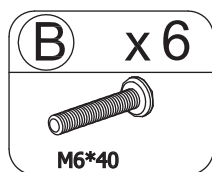

BHMA/STEP: 6

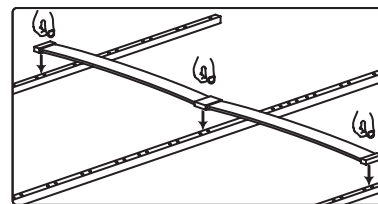
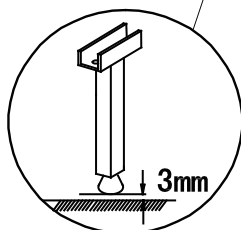
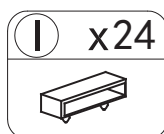
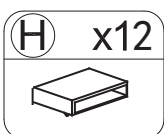
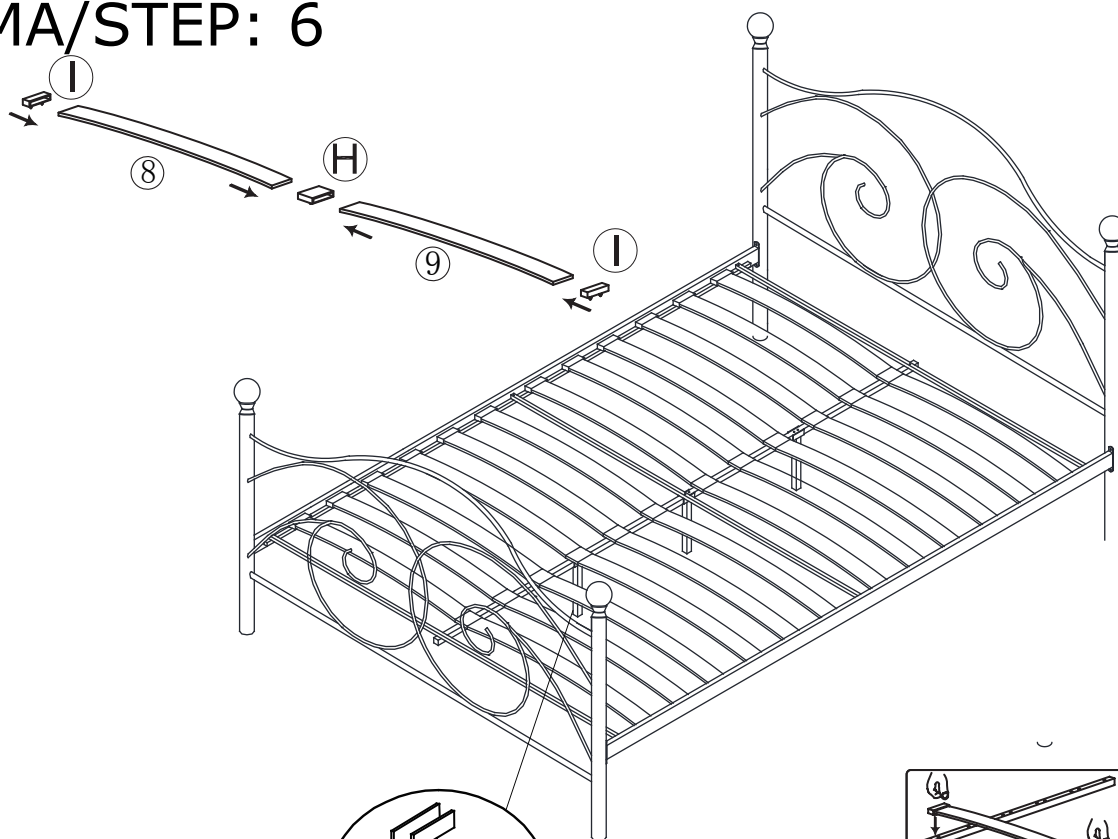

***ΠΡΟΣΟΧΗ:**

ΜΗΝ ΣΦΙΞΕΤΕ ΥΠΕΡΒΟΛΙΚΑ ΤΙΣ ΒΙΔΕΣ ΣΤΑ ΜΕΣΑΙΑ ΠΟΔΑΡΑΚΙΑ ΣΤΗΡΙΞΗΣ.

ΣΤΟ ΤΕΛΟΣ ΤΗΣ ΣΥΝΑΡΜΟΛΟΓΗΣΗΣ ΘΑ ΠΡΕΠΕΙ ΝΑ ΥΠΑΡΧΕΙ ΚΕΝΟ ΑΝΑΜΕΣΑ ΣΤΟ ΠΟΔΑΡΑΚΙ & ΤΟ ΠΑΤΩΜΑ 3mm.

ΤΑ ΠΟΔΑΡΑΚΙΑ ΘΑ ΑΚΟΥΜΠΗΣΟΥΝ ΣΤΟ ΠΑΤΩΜΑ ΜΟΝΟ ΟΤΑΝ ΥΠΑΡΞΕΙ ΒΑΡΟΣ ΠΑΝΩ ΣΤΟ ΚΡΕΒΑΤΙ.

ΜΗΝ ΣΥΡΕΤΕ ΤΟ ΚΡΕΒΑΤΙ ΜΑΖΙ ΜΕ ΤΟ ΣΤΡΩΜΑ. ΕΠΙΣΗΣ ΜΗΝ ΤΟ ΣΥΡΕΤΕ ΠΑΝΩ ΣΕ ΧΑΛΙ Ή ΣΕ ΤΡΑΧΕΙΑ ΕΠΙΦΑΝΕΙΑ.

***ATTENTION:**

DO NOT OVERFASTEN THE SCREWS OF THE MIDDLE SUPPORT LEGS.

AFTER YOU FINISH ASSEMBLING THE BED THERE HAS TO BE A GAP OF 3 mm BETWEEN THE LEGS AND THE FLOOR.

THE LEGS WILL TOUCH THE GROUND ONLY AFTER THERE IS WEIGHT ON THE BED.

DO NOT DRAG THE BED ALONG WITH THE MATTRESS. ALSO DO NOT DRAG THE BED ON CARPETS OR ANY ROUGH SURFACE.