

# AMOS 80 · AMOS 100

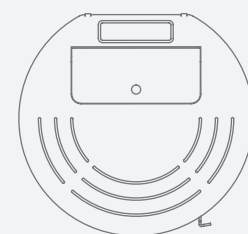

## SPECIAL FEATURES

- Rear smoke outlet
- Cast iron brazier
- Reinforced steel structure
- Removable ash drawer
- Flue protection system
- Tank / stove overheating protection system
- Daily programming 4 switch-ons / 4 switch-offs
- High performance heat exchanger

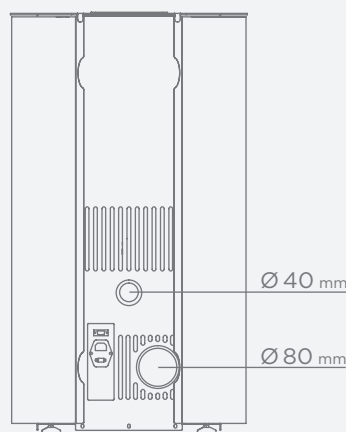
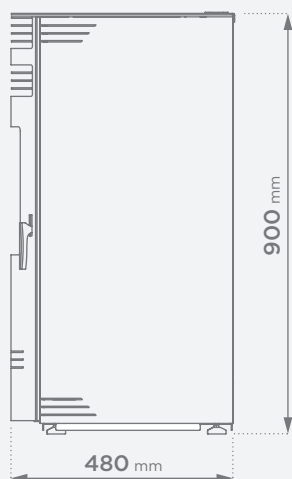
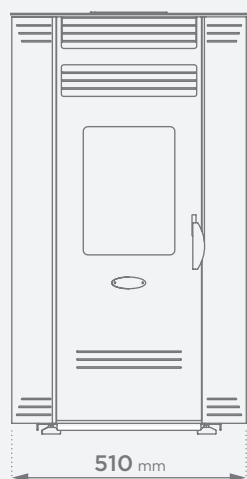

Technical data	AMOS 80	AMOS 100
Global power	7.7 kW	9.0 kW
Nominal power	3 - 6,7 kW	3 - 8.2 kW
Energy rating	A+	A+
Efficiency	91.6 %	93.4 %
Hourly consumption	0.6 - 1.5 kg/h	0.6 - 1.8 kg/h
Volume heated	120 - 240 m <sup>3</sup>	120 - 265 m <sup>3</sup>
Tank capacity	15 kg (pellet Ø 6 mm)	15 kg (pellet Ø 6 mm)
Power autonomy	10 - 26 h	9 - 26 h
Air / flue pipe	Ø 40 / 80 mm	Ø 40 / 80 mm
Max air flow rate	190 m <sup>3</sup> /h	230 m <sup>3</sup> /h
Electric consumption	47 - 63 W	47 - 65 W
Weight	75 kg	78 kg