

Robert Bosch Power Tools GmbH  
70538 Stuttgart  
GERMANY

[www.bosch-do-it.com](http://www.bosch-do-it.com)

F 016 L81 292 (2017.07) 0 / 69



## AdvancedAquatak

150 | 160



- en Original instructions
- cn 正本使用说明书
- tw 原始使用說明書
- ko 사용 설명서 원본
- th หนังสือคู่มือการใช้งานฉบับต้นแบบ
- id Petunjuk-Petunjuk untuk Penggunaan Orisinal
- vi Bản gốc hướng dẫn sử dụng





2 |



English ..... Page 3  
 中文 ..... 页 12  
 中文 ..... 頁 18  
 한국어 ..... 페이지 25  
 ภาษาไทย ..... หน้า 32  
 Bahasa Indonesia ..... Halaman 41  
 Tiếng Việt ..... Trang 49

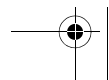
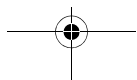
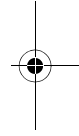
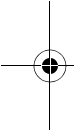

## English

### Safety Notes

#### Explanation of symbols



General hazard safety alert.



Never direct the water jet at people, animals, the unit or electric components.

Warning: High pressure jets can be dangerous if subject to misuse.



**According to the applicable regulations, the appliance must never be used on the drinking water network without a system separator. Use a separator as per IEC 61770 Type BA.**

**Water flowing through a system separator is considered not drinkable.**



The **AdvancedAquatak 150** is intended for use only in premises having a service current capacity  $\geq 100$  A per phase, supplied from a distribution network having a nominal voltage of 230 V. If in doubt please contact your Supply Authority.

#### Safety Notes for pressure washer



**Read all safety warnings and all instructions.** Failure to follow the warnings and instructions may result in electric shock, fire and/or serious injury.

**The warning and information signs attached to the unit provide important information for safe operation.**

**Apart from the information in the operating instructions comply with the general safety regulations and regulations for the prevention of accidents.**

#### Connecting to the mains

- ▶ The voltage indicated on the rating plate must correspond to the voltage of the power source.
- ▶ We recommend that this equipment is only connected into a socket which is protected by a circuit-breaker that would be actuated by a 30 mA residual current.
- ▶ Remove the plug from socket whenever the machine is left unattended for any period.
- ▶ The electric supply installation should comply with IEC 60364-1.
- ▶ If the supply cord is damaged, it must be replaced by the manufacturer, its service agent or similarly qualified persons in order to avoid a hazard.
- ▶ If the plug is damaged, pay attention to the following:
- ▶ Plugs and sockets situated near the work site or outdoors should be to class IP 55 of BS 5490 to provide adequate protection against ingress of water, etc. and cable entries require effective sealing. Rubber shrouds should be provided over cable glands. Drip-proof (class IP X2 of BS 5490) plugs and sockets to BS 4343 are suitable for use indoors where the plug is away from the water spray area where the appliance is in use.

## 4 | English

- ▶ Never touch the mains plug with wet hands.
- ▶ Do not pull plug while operating the device.
- ▶ Do not run over, crush or pull the power supply cord or extension cord, otherwise it may be damaged. Protect the cable from heat, oil and sharp edges.
- ▶ Do not use the unit, if the power supply cord or important parts, e. g. high-pressure hose, power gun or safety devices are damaged.
- ▶ Warning: Inadequate extension cords can be dangerous.
- ▶ If an extension cord is used, the plug and socket must be of watertight construction. The extension cord must have a cross section in accordance with the operating instructions and be protected against splashed water. The connection must not be in water.
- ▶ When replacing plugs on the power supply cable or extension lead the spray water guard and mechanical stability must remain intact.

**Water connection**

- ▶ Comply with the regulations of your water supply company.
- ▶ All connecting hoses must have properly sealed joints.
- ▶ Make sure that the supply hose is at least 12.7 mm (1/2") in diameter and is reinforced.
- ▶ The appliance should never be used on the drinking water supply without a back flow valve. Water which has passed the back flow valve is regarded as undrinkable.
- ▶ The high-pressure hose must not be damaged (danger of bursting). A damaged high-pressure hose must be replaced immediately. Only use hoses and connections recommended by the manufacturer.
- ▶ High-pressure hoses, fittings and couplings are important for the safety of the appliance. Use only hoses, fittings and couplings recommended by the manufacturer.
- ▶ Only clean or filtered water should be used for intake.

**Application**

- ▶ Before use, check that the unit and operating equipment are in perfect condition and are safe to operate. Do not use the unit if it is not in perfect condition.
- ▶ Do not direct the jet against yourself or others in order to clean clothes or footwear.
- ▶ Do not use solvent-containing liquids, undiluted acids, acetone or solvents! This includes petrol, paint thinners, heating oil. The sprayed vapour is highly flammable, explosive and toxic.
- ▶ The appropriate safety regulations must be observed when using the unit in dangerous areas (e. g. petrol stations). It is forbidden to operate the unit in potentially explosive locations.
- ▶ The unit must be placed on a solid base.
- ▶ Take care if using the machine in a confined space ensuring that there is adequate ventilation. Ensure that all

- vehicles are switched off at all times whilst cleaning.
- ▶ Operation of this machine requires both hands to be used at all times. Do not operate from a ladder. Take care when using the machine on balconies or other raised areas ensuring that you can see any edges at all times.
  - ▶ Only use detergents recommended by the manufacturer. Comply with the application, disposal and warning instructions of the detergent manufacturers.
  - ▶ All current-conducting components in the working area must be protected against splashed water.
  - ▶ The gun trigger must not be jammed in position "ON" during operation.
  - ▶ Wear suitable protective clothing to protect against splashing from some parts. Do not use the appliance within the range of persons unless they also wear protective clothing.
  - ▶ If necessary wear personal protective equipment (PPE) e. g. safety goggles, breathing protection etc to protect against water, particles and/or aerosols sprayed back from parts.
  - ▶ High pressure may cause objects to rebound. If necessary wear suitable personnel protective equipment such as safety goggles.
  - ▶ Vehicle tyres/tyre valves may only be cleaned from a minimum distance of 30 cm, otherwise the vehicle tyre/tyre valve could be damaged by the high-pressure jet. The first indication of this is a discoloration of the tyre. Damaged vehicle tyres/tyre valves can be extremely dangerous.
  - ▶ Materials containing asbestos and other materials which contain substances which are hazardous to your health must not be sprayed.
  - ▶ Detergents must not be used undiluted. The products are safe to use as they contain no acids, alkalis or substances which are detrimental to the environment. We recommend that the detergents are kept out of the reach of children. If detergent comes into contact with the eyes, wash immediately with plenty of water and if swallowed contact a doctor immediately.
- ▶ **Never use the pressure washer without the filter or with a dirty or damaged filter.** Using the pressure washer without a filter or with a dirty or damaged filter may invalidate the warranty.
- ▶ Metal parts may become hot after prolonged usage, if necessary wear protective gloves.
  - ▶ Avoid high pressure washing in bad weather conditions especially when there is a risk of lightning.

### Operation

- ▶ The operator must use the unit in accordance with the regulations. He/she must take local conditions into account and be aware of other people, especially children, when operating the unit.
- ▶ The unit may only be used by authorised persons who have received training or have demonstrated their ability to operate the unit. The unit must not be operated by children or

## 6 | English

juveniles (danger of accidents due to incorrect use of the unit).

- ▶ Never allow children, persons with physical, sensory or mental limitations or a lack of experience and/or knowledge and/or people unfamiliar with these instructions to use the garden tool. Local regulations may restrict the age of the operator.
- ▶ Children should be supervised to ensure that they do not play with the machine.
- ▶ The unit must never be left unsupervised while the unit is switched on.
- ▶ The water jet from the high-pressure nozzle produces a recoil on the gun. You should therefore hold the gun and spray lance firmly with both hands.
- ▶ Never use a roto nozzle or pencil jet to clean motor vehicles.

### Transport

- ▶ Switch off the motor and secure the unit before transporting.

### Maintenance







- ▶ Switch off the unit prior to all cleaning and maintenance work and before replacing components. Pull out the mains plug if the unit is mains-operated.
- ▶ Repairs may only be carried out by authorised Bosch Service Centres.

### Accessories and spare parts

- ▶ Accessories and spare parts which have been approved by Bosch must be used. Original accessories and spare parts guarantee that the unit can be operated safely and without any breakdowns.

### Symbols

The following symbols are important for reading and understanding the operating instructions. Please take note of the symbols and their meaning. The correct interpretation of the symbols will help you to use the machine in a better and safer manner.

Symbol	Meaning
	Movement direction
	Reaction direction
	Weight
	On
	Off
Lo	Low pressure
Hi	High pressure
	Accessories

### Intended Use

The product is intended for cleaning areas and objects outside the house, tools, vehicles and boats, if the appropriate accessories and cleaning agents approved by Bosch are used. Intended use is related to operation within 0°C and 40°C ambient temperature.

This product should not be used for professional use.

## Technical Data

Pressure washer		AdvancedAquatak 150	AdvancedAquatak 160
Article number		3 600 HA7 7..	3 600 HA7 8..
Rated power	kW	2.2	2.6
Supply temperature max.	°C	40	40
Supply rate min.	l/min	8	9.5
Allowable pressure	MPa	15	16
Rated pressure	MPa	11	12
Rated Flow	l/min	7.5	8.5
Maximum inlet pressure	MPa	1	1
Autostop function		●	●
Weight according to EPTA-Procedure 01:2014	kg	21.1	23.4
Protection class		⊕ / I	⊕ / I
Serial number	See serial number (rating plate) on pressure washer		

The values given are valid for a nominal voltage [U] of 230 V. For different voltages and models for specific countries, these values can vary.

Starting cycles generate brief voltage drops. Interference with other equipment/machines may occur in case of unfavourable mains system conditions. Malfunctions are not to be expected for system impedances below 0.276 ohm. If in doubt please contact your Supply Authority.

## Mounting and Operation

Action	Figure	Page
Delivery Scope	1	59
Adjusting the Handle	2	60
Connecting high pressure water supply hose/nozzle	3	60
Connecting to the water supply	4	61
Switching On and Off	5-6	61
Clean the water filter	7	62
Clean nozzle	8	62
Connecting high pressure gun to lance	9	62
Tube Assembly	10	63
Connect detergent bottle	11	63
Variable Fan lance		
Connecting high pressure gun to lance		
Adjust water jet	12	64
Roto lance		
Connecting high pressure gun to lance		
Adjust water jet	13	65
Gun storage	14	66
Storage	15	66
Transport	16	67
Selecting Accessories	17	68

## Starting

### For Your Safety



**Warning! Switch off, remove plug from mains before adjusting, cleaning or if cable is cut, damaged or entangled.**

The operating voltage is 230 V AC, 50 Hz (for non-EU countries 220 V, 240 V as applicable). Only use approved extension cables. Contact your Bosch Service Centre for details.

If you want to use an extension cable when operating your high pressure washer, only the following cable dimensions should be used:

– 2.5 mm<sup>2</sup> – max length 25 m

Note: If an extension cable is used it must be earthed and connected through the plug to the earth cable of your supply network in accordance with prescribed safety regulations.

If in doubt contact a qualified electrician or the nearest Bosch Service Centre.



**WARNING! Inadequate extension cables can be dangerous. Extension cable, plug and socket must be of watertight construction and intended for outdoor use.**

Cable connections should be kept dry and off the ground.

For increased electrical safety use a Residual Current Device (RCD) with a tripping current of not more than 30 mA. Always check your RCD every time you use it.

If the supply cord is damaged, it must be replaced by a Bosch Service Centre.

For products **not sold in GB:**

**WARNING:** For your safety, it is required that the plug attached to the machine is connected with the extension cord. The coupling of the extension cord must be protected against splash water, be made of rubber or coated with rubber. The extension cord must be used with a cable strain relief.

To prevent damage to the appliance, do not allow it to operate dry.

**Products sold in GB only:** Your product is fitted with an BS 1363/A approved electric plug with internal fuse (ASTA approved to BS 1362).

## 8 | English

If the plug is not suitable for your socket outlets, it should be cut off and an appropriate plug fitted in its place by an authorised customer service agent. The replacement plug should have the same fuse rating as the original plug. The severed plug must be disposed of to avoid a possible shock hazard and should never be inserted into a mains socket elsewhere.

## Operation

### Starting

Attach water supply hose (not supplied) to the mains water supply and machine.

Connect the product to the mains supply ensuring that the mains switch is in the off position.

Open water tap.

Press the safety lock (back button on the gun handle) to release the trigger. Fully press the trigger until there is a constant flow of water to clear the air from the machine and water supply hose. Release trigger. Press the safety lock (front button on the gun handle).

Turn button on main switch. Point the power gun downwards. Press the trigger safety lock to release the trigger. Fully press the trigger.

### Autostop function

The machine is designed to switch off the motor when the trigger is released on the gun.

## Working Advice

### General

Ensure that the pressure washer is on level ground.

Do not overreach with the high pressure hose or move the pressure washer by pulling the hose, this could cause the machine to become unstable and fall over.

Do not kink or drive a motor vehicle over the high pressure hose. Do not expose the high pressure hose to sharp edges or corners.

- ▶ Never use a roto nozzle or pencil jet to clean motor vehicles.

**WARNING!** The Patio Cleaners supplied are only intended to be used on flat surfaces! Do not attempt to use them on steps. Never attempt to touch the rotating nozzle while operating the machine!

### Working advice for cleaning with detergents

- ▶ **Only use cleaning agents suitable specifically for high pressure washers.**

We recommend that you use detergent sparingly for the sake of the environment. Observe the recommended dilution on the detergent label.

The high-pressure foam nozzle supplied with this product includes a regulator to control detergent use. Adjust as required.

### Recommended cleaning method

**Step 1:** Attach the fixed fan nozzle and remove the heavy dirt.

**Step 2:** Attach the foam bottle and spray on the detergent sparingly.

**Step 3:** Rinse off the loosened dirt and detergent with the fan nozzle.

**Note:** When cleaning a vertical surface spray off dirt/detergent from the bottom and work in an upwards direction. Rinse from the top and work downwards.

### Use with alternative water sources

This high-pressure washer will self prime and can draw water from water tanks and natural water sources. It's **IMPORTANT** that the water is clean and the BOSCH inlet filter is clear and fitted to the machine.

### Open tanks/containers and natural water sources

Use the Self Priming accessory kit comprising:

- Inlet strainer with non return valve
- 3 m reinforced supply hose
- Universal coupling to the pressure washer

This enables the pressure washer to draw water up to 0.5 m above the water level in the source in approximately 15 seconds.

Submerge the 3 m hose in water to displace the air. Connect the 3 m supply hose to the pressure washer ensuring that the inlet strainer remains submerged in the water source.

Run the pressure washer with the gun disconnected until a steady flow of water appears from the high pressure hose. Stop if this has not been achieved within 25 seconds and check all the connections. Switch off and connect the gun, lance and nozzle to operate.

It is important to ensure that all hose and coupling connections are of good quality, air tight and that all washers are in good condition and correctly seated in place. Failure to do so may affect the self priming performance.

### Water Tanks with outlet connections

When connecting the pressure washer to a water tank with a suitable tap outlet, first connect the supply hose (not provided) to the tank outlet, open the tap to allow the water to displace all the air in the hose and then connect to the pressure washer.



## Troubleshooting

Problem	Possible Cause	Corrective Action
Motor refuses to start	Plug not connected	Connect plug
	Mains socket faulty	Use another socket
	Fuse faulty/blown	Replace fuse
	Extension cable damaged	Try without extension cable
	Motor protector has activated	Allow to cool for 15 minutes
	Frozen	Wait for pump/water supply hose/accessory to thaw
Motor stops	Fuse faulty/blown	Replace fuse
	Wrong mains voltage	Check that mains voltage corresponds to specifications on the model tag
	Motor protector has activated	Allow to cool for 15 minutes
Fuses blow	Fuses incorrectly rated	Change to a mains supply higher than the pressure washer amp consumption
Motor starts but no pressure	Nozzle partly blocked	Clean nozzle
Motor "sounds" but fails to start	Insufficient power supply	Check that the voltage of the mains power supply line is the same as that on the plate
	Voltage loss due to use of extension cable	Check characteristics of extension cable
	Appliance not used for a long period of time	Contact your Bosch Service Centre
	Problems with TSS (Total Stop System) device	Contact your Bosch Service Centre
Pressure pulsating	Air in the inlet water supply hose/pump	Allow pressure washer to run with open spray handle and nozzle at low pressure until regular working pressure is obtained
	Inadequate water supply	Check that the water supply corresponds to specifications. The minimum specification for the water supply hose is 1/2" or 13 mm diameter
	Water filter blocked	Clean water filter
	Water supply hoses squeezed	Straighten out kinked water supply hoses
	High pressure hose too long	Remove high pressure extension hose. Retry (extension hose max. 7 m)
Pressure too low, but steady Note: Several types of accessory will normally deliver a lower pressure	Nozzle worn	Change the nozzle
	Start/stop valve worn	Activate trigger five times in quick succession
Motor starts up but with restricted or no working pressure	No water supply	Connect water supply
	Water filter clogged up	Clean the water filter
	Nozzle clogged up	Clean nozzle
The pressure washer starts irregularly by itself	Pump/power gun leaky	Contact your Bosch Service Centre
Water leaks from machine	Leaking pump	A slight water leak is permissible; in case of excessive leak, contact Bosch Service Centre

## Maintenance and Service

### Maintenance

- **Stop, remove plug from the power supply and disconnect from water supply.**

**Note:** To ensure long and reliable service, carry out the following maintenance regularly.

Regularly check for obvious defects such as loose fixings, and worn or damaged components.

**10 | English**

Check that covers and guards are undamaged and correctly fitted. Carry out necessary maintenance or repairs before using.

If the replacement of the supply cord is necessary, this has to be done by Bosch or an authorized Bosch service agent in order to avoid a safety hazard.

**After use/Storage**

Turn the main switch off and operate the trigger to drain the water from the high pressure hose.

Clean the exterior of the machine thoroughly using a soft brush or cloth. Do not use water, solvents or polishes. Remove all debris, especially from the ventilation slots.

End of season storage: Drain water out of pump running motor for a few seconds. Pull trigger to release all water.

Do not place other objects on top of the machine.

Store in a frost-free area.

Ensure cables are not trapped when storing. Do not kink high pressure hose.

**After-sales Service and Application Service****www.bosch-do-it.com**

In all correspondence and spare parts orders, please always include the 10-digit article number given on the type plate of the machine.

**People's Republic of China****China Mainland**

Bosch Power Tools (China) Co., Ltd.  
567, Bin Kang Road  
Bin Jiang District 310052  
Hangzhou, P. R. China  
Service Hotline: 4008268484  
Fax: (0571) 87774502  
E-Mail: contact.ptcn@cn.bosch.com  
www.bosch-pt.com.cn

**HK and Macau Special Administrative Regions**

Robert Bosch Hong Kong Co. Ltd.  
21st Floor, 625 King's Road  
North Point, Hong Kong  
Customer Service Hotline: +852 2101 0235  
Fax: +852 2590 9762  
E-Mail: info@hk.bosch.com  
www.bosch-pt.com.hk

**Indonesia**

PT Robert Bosch  
Palma Tower 10<sup>th</sup> Floor  
Jl. RA Kartini II-S Kaveling 6 Sek II  
Pondok Pinang, Kebayoran Lama  
Jakarta Selatan 12310  
Indonesia  
Tel.: (021) 3005 5800  
Fax: (021) 3005 5801  
E-Mail: boschpowertools@id.bosch.com  
www.bosch-pt.co.id

**Philippines**

Robert Bosch, Inc.  
28th Floor Fort Legend Towers,  
3rd Avenue corner 31st Street,  
Fort Bonifacio Global City,  
1634 Taguig City, Philippines  
Tel.: (02) 8703871  
Fax: (02) 8703870  
matheus.contiero@ph.bosch.com  
www.bosch-pt.com.ph

Bosch Service Center:  
9725-27 Kamagong Street  
San Antonio Village  
Makati City, Philippines  
Tel.: (02) 8999091  
Fax: (02) 8976432  
E-Mail: rosalia.dagdagan@ph.bosch.com

**Malaysia**

Robert Bosch Sdn. Bhd.  
No. 8A, Jalan 13/6  
G.P.O. Box 10818  
46200 Petaling Jaya  
Selangor, Malaysia  
Tel.: (03) 79663194  
Fax: (03) 79583838  
E-Mail: cheehoe.on@my.bosch.com  
Toll-Free: 1800 880188  
www.bosch-pt.com.my

**Thailand**

Robert Bosch Ltd.  
Liberty Square Building  
No. 287, 11 Floor  
Silom Road, Bangrak  
Bangkok 10500  
Tel.: 02 6393111  
Fax: 02 2384783  
Robert Bosch Ltd., P. O. Box 2054  
Bangkok 10501, Thailand  
www.bosch.co.th  
Bosch Service – Training Centre  
La Salle Tower Ground Floor Unit No.2  
10/11 La Salle Moo 16  
Srinakharin Road  
Bangkaew, Bang Plee  
Samutprakarn 10540  
Thailand  
Tel.: 02 7587555  
Fax: 02 7587525

**Singapore**

Powerwell Service Centre Ptd Ltd  
65 Ubi Crescent, #06-03 Hala Centre  
Singapore 408559  
Tel.: 6746 9770/71  
Fax: 6746 9760  
E-Mail: powerwellsc@gmail.com  
Toll-Free: 1800 3338333  
www.bosch-pt.com.sg

**Vietnam**

Robert Bosch Vietnam Co. Ltd  
 13th Floor, 194 Golden Building  
 473 Dien Bien Phu Street  
 Ward 25, Binh Thanh District  
 84 Ho Chi Minh City  
 Vietnam  
 Tel.: (08) 6258 3690  
 Fax: (08) 6258 3692  
 Hotline: (08) 6250 8555  
 E-Mail: tuvankhachhang-pt@vn.bosch.com  
 www.bosch-pt.com.vn  
 www.baohanhbosch-pt.com.vn

**Australia, New Zealand and Pacific Islands**

Robert Bosch Australia Pty. Ltd.  
 Power Tools  
 Locked Bag 66  
 Clayton South VIC 3169  
 Customer Contact Center  
 Inside Australia:  
 Phone: (01300) 307044  
 Fax: (01300) 307045  
 Inside New Zealand:  
 Phone: (0800) 543353  
 Fax: (0800) 428570  
 Outside AU and NZ:  
 Phone: +61 3 95415555  
 www.bosch-pt.com.au  
 www.bosch-pt.co.nz

**Egypt**

Unimar  
 20 Markaz kadmat  
 El tagmoa EL Aoul – New Cairo  
 Tel: +2 02 224 76091 - 95 / + 2 02 224 78072 - 73  
 Fax: +2 02 224 78075  
 E-Mail: adelzaki@unimaregypt.com

**Ethiopia**

Forever plc  
 Kebele 2,754, BP 4806,  
 Addis Ababa, Ethiopia  
 Tel: +251 111 560 600, +251 111 560 600  
 E-Mail: foreverplc@ethionet.et

**Nigeria**

C. Woermann Ltd.  
 P.O. Box 318  
 6, Badejo Kalesanwo Street  
 Matori Industrial Estate  
 Lagos, Nigeria  
 Tel: +234 17 736 498, +234 17 730 904  
 E-Mail: d.kornemann@woermann-nigeria.com

**Republic of South Africa**

**Customer service**  
 Hotline: (011) 6519600

**Gauteng – BSC Service Centre**

35 Roper Street, New Centre  
 Johannesburg  
 Tel.: (011) 4939375  
 Fax: (011) 4930126  
 E-Mail: bsctools@icon.co.za

**KZN – BSC Service Centre**

Unit E, Almar Centre  
 143 Crompton Street  
 Pinetown  
 Tel.: (031) 7012120  
 Fax: (031) 7012446  
 E-Mail: bsc.dur@za.bosch.com

**Western Cape – BSC Service Centre**

Democracy Way, Prosperity Park  
 Milnerton  
 Tel.: (021) 5512577  
 Fax: (021) 5513223  
 E-Mail: bsc@zsd.co.za

**Bosch Headquarters**

Midrand, Gauteng  
 Tel.: (011) 6519600  
 Fax: (011) 6519880  
 E-Mail: rbsa-hq.pts@za.bosch.com

**Environmental Protection**

Chemicals dangerous to the environment must not be allowed to enter the ground, ground water or ponds, streams, etc.

For the use of cleaning agents, observe the instructions on the package and the prescribed concentration exactly.

For the cleaning of motor vehicles the local regulations should be observed: Do not allow oil sprayed off to enter into the ground water. Recycle raw materials instead of waste disposal.

**Disposal**

The pressure washer, accessories and packaging should be sorted for environmental-friendly recycling.

Do not dispose of pressure washers into household waste!

**Only for EC countries:**

According to the European directive 2012/19/EU for Waste Electrical and Electronic Equipment and its implementation into national law, electrical and electronic equipment that are no longer usable must be collected separately and disposed of in an environmentally correct manner.

**Subject to change without notice.**

## 中文

### 安全规章

#### 图标说明



一般性警告。



不可以把喷射出的水流朝向人、动物、机器或电动零件。

注意：如果使用不当，高压水柱可能造成危险。



根据适用的法规，如果机器不具备系统分离功能，便不可以连接到饮用水的供应系统上。根据 IEC 61770，得使用 BA 型的系统分离器。

流过系统分离器的水，已经不再是饮用水。



**AdvancedAquatak 150** 是针对每相线连接电流  $\geq 100$  安培，以及电压为 230 伏特的电源所设计。如有供电方面的疑问，请联系您当地的电力公司。

### 高压清洁机的安全规章



阅读所有的警告提示和指示。如未确实遵循警告提示和指示，可能导致电击，火灾并且 / 或其他的严重伤害。

机器上的警告和提示牌提供了重要的讯息，能够确保操作安全。

除了遵循使用说明书上的指示之外，还必须兼顾一般性的安全规章和意外防范规定。

### 用电须知

- ▶ 电源的电压必须和机器铭牌上提供的电压一致。
- ▶ 最好将机器插在配备了 30 mA 剩于电流保护开关的插座上。
- ▶ 即使您只是暂时离开机器，也要从插座上拔出插头。
- ▶ 电源的电压必须符合 IEC 60364-1 的要求。
- ▶ 如果需要更换电线，得由机器的制造商、经过制造商授权的客服中心或合格的专业人员执行此工作，以避免危害安全。
- ▶ 不可以使用潮湿的手拿电线。
- ▶ 操作机器时不要拉扯插头。
- ▶ 不可以辗过、压过电线或延长线，也不可以拉扯它们。这样会损坏电线。电线必须远离高温、油垢和锋利的边缘。
- ▶ 如果电线或重要的零件，例如高压软管、喷射枪或安全装备等损坏了，便不可以使用机器。
- ▶ 注意：不符合规定的延长线可能造成危险。
- ▶ 使用延长线时，它的插头和连接装备都必须是防水的。延长线横截面的尺寸必须符合使用说明书上的规定，延长线也要具备防水花的功能。插头不可以浸泡在水中。
- ▶ 更换电线或延长线的插头时，不可以破坏电线或延长线的防水安全性能和稳定性。

## 用水须知

- ▶ 请注意贵国供水单位的规定。
- ▶ 所有水管的接头都不可以漏水。
- ▶ 只能使用直径 12, 7 毫米 (1/2") 的增强软管。
- ▶ 把机器连接在饮用水源上时，务必在机器上安装逆流阀。通过逆流阀的水则不适合饮用。
- ▶ 高压软管不能受损（有爆裂的危险）。高压软管如果损坏了必须马上更换。只能使用制造商推荐的水管和连接件。
- ▶ 高压软管，节流装备和连接装备都攸关机器的安全性能。只能使用机器制造厂商推荐的软管，节流装备和连接装备。
- ▶ 水源接头只能连接干净或经过过滤的水。

## 使用须知

- ▶ 正式操作之前，先检查机器和附件是否一切正常，是否会危害操作安全。如果发现任何故障则不可以使用机器。
- ▶ 不可以使用水流清洗自己的或别人的衣服、鞋子。
- ▶ 不可以吸汲含有溶解剂的液体、未稀释的酸性液体、丙酮或溶解剂，例如汽油、颜料稀释剂或柴油等。因为它们的喷雾极度易燃，容易爆炸并且有毒。
- ▶ 在危险的场所（例如加油站）使用本机器，务必遵守有关的安全规定。不可以有爆炸危险的场所使用本机器。

- ▶ 机器必须放在平稳的地面上。
- ▶ 在密闭的空间使用本机器时要确保通风良好。并确定清洁过程中车辆处于熄火状态（已经关闭马达）。
- ▶ 必须用双手操控高压清洁机。不可以在梯子上使用本机器。当在阳台或其他凸起的表面工作时，要确保随时能看到所有的场地边缘。
- ▶ 只能使用机器制造商推荐的清洁剂。并确实遵循机器制造商提出的使用说明、废弃处理建议和警告提示。
- ▶ 做好工作场所中所有会导电零件的防水措施。
- ▶ 操作机器时，不可以让喷射枪上的启动开关，卡牢在 "ON" 的位置。
- ▶ 穿着能够防水花的合适防护衣，如果在水流的喷射范围内有旁人则不可以使用机器，除非他穿著了防护衣。
- ▶ 必要时得穿上合适的防护装备（PSA）来防范喷溅的水花，例如佩戴护目镜，防尘面具等来避开从物体上反弹的水，颗粒和 / 或气溶胶。
- ▶ 高压可能造成物体回弹。必要时，得穿上合适的个人防护装备，例如护目镜。
- ▶ 为了避免高压水流造成伤害，清洁汽车轮胎和阀门时至少要保持 30 公分的距离。如果轮胎受损了，首先会出现轮胎变色的情

## 14 | 中文

形。受损的轮胎 / 阀门都可能造成生命危险。

- ▶ 不可以喷洗含石棉和其它含有毒素的物体。
- ▶ 经推荐的清洁剂必须先稀释了再使用。这些产品是安全，因为它们不含酸、碱或 其它有害环境的物质。我们建议您把清洁剂，存放在儿童无法取得之处。清洁剂如果接触眼睛，必须马上用水彻底清洗。误食清洁剂必须马上就医。
- ▶ **使用高压清洁机时务必安装滤网，勿使用肮脏的或已经损坏的滤网。** 如果使用高压清洁机时未安装滤网，或是用了肮脏的、已经损坏的滤网，将导致保修失效。
- ▶ 长时间使用后，金属零件可能变烫。如果必要的话得戴上防护手套。
- ▶ 不要在恶劣的天气条件下特别是在雷雨来临时，操作高压清洁机。

**操作须知**

- ▶ 操作者务必按照规定使用机器。并且要注意操作现场的实际状况。工作时务必考虑到旁人，尤其是儿童。
- ▶ 只有经过操作指导的人或可以证明能够操作本机器的人，才可以使用它。儿童或青少年不可以使用本机器。

- ▶ 不允许儿童，生理、感官或经神能力受限的人，经验不够和 / 或知识不足和 / 或不熟悉本指示的人操作本庭园工具。您本国的法规可能也会限制使用者的年龄。
- ▶ 看顾好小孩，以确保他们不会玩弄本庭园工具。
- ▶ 开动机器后，绝对不可以弃机器于不顾。
- ▶ 透过高压喷射出的水柱可能造成危险。因此要用双手握牢喷射枪和枪体。
- ▶ 不可以使用旋转喷头和线状水柱清洗车辆。

**搬运须知**

- ▶ 搬运之前必须先关闭机器并固定好机器。

**维修**

- ▶ 清洁、维修机器和更换附件之前，都要先关闭机器。如果机器连接在插座上则要拔出插头。
- ▶ 维修的工作只能交给博世授权的维修工厂执行。

**附件和备件**

- ▶ 只能使用制造厂商规定的附件和备件。使用原厂的附件和原厂的备件才能够确保机器的正常功能。

**代表符号**

以下的符号可以帮助您正确地使用本机器。请仔细阅读各符号及它们的代表意思。正确了解各符号所代表的意义，可以帮助您更有把握更安全地操作本机器。

符号	含义
	移动方向
	反应方向
	重量
	开启
	关闭

符号	含义
Lo	较低的压力
Hi	较高的压力
	附件

## 按照规定使用机器

本机器可以清洗户外的地面和物体，安装了合适的附件及经过博世认可的清洁剂后，也能够使用本工具清洗机器，车辆和船。

合适的操作环境温度位在摄氏 0 度和 40 度之间。

本产品不适合从事工业用途。

## 技术数据

高压清洁机		AdvancedAquatak 150	AdvancedAquatak 160
物品代码		3 600 HA7 7..	3 600 HA7 8..
额定输入功率	kW	2,2	2,6
进口温度最大	° C	40	40
进口水流最小	公升 / 每分	8	9,5
许可压力	MPa	15	16
额定压力	MPa	11	12
流量	公升 / 每分	7,5	8,5
最大进口压力	MPa	1	1
自动关机功能		●	●
重量符合 EPTA-Procedure 01:2014	公斤	21,1	23,4
绝缘等级		⊕ / I	⊕ / I
序列号码		参考序列号码 (型号铭牌) 在高压清洁机上	

本说明书提供的参数是以 230 V 为依据，于低电压地区，此数据有可能不同。

开动电动工具时，电压会突然下降。如果电源网络状况不佳，可能会干扰其它机器。在电源阻抗小于 0,276 欧姆时不会产生干扰。如有疑问，请联系您当地的电力公司。

## 安装和操作

执行目的	图片	页数
供货范围	1	59
调节手柄	2	60
连接高压软管 / 喷射枪	3	60
连接水源	4	61
开动 / 关闭	5 - 6	61
清洁滤网	7	62
清洁喷嘴	8	62
将枪管连接在喷射枪上	9	62
插上喷嘴	10	63
连接洗涤剂罐	11	63
带可变扇形射束的喷枪		
将枪管连接在喷射枪上		
调整喷嘴的水柱	12	64
带旋转射束的喷枪		
将枪管连接在喷射枪上		
调整喷嘴的水柱	13	65

执行目的	图片	页数
储放喷射枪	14	66
储存	15	66
搬运	16	67
选择附件	17	68

## 操作

### 针对您的安全



**注意！** 维修或清洁机器之前，先关闭机器并从插座上拔出插头。如果电线受损、被割坏或缠绕在一起也要执行以上的防范措施。

工作电压是 230 V AC, 50 Hz (针对非欧盟国家 220 V, 240 V 视机型而定)。只能使用经过许可的延长线，有关信息请联系授权的顾客服务中心。

操作本高压清洁机时，如果必须使用延长线，该延长线的截面积必须符合以下的规定：

– 2,5 毫米<sup>2</sup> 到 最大 25 米长

## 16 | 中文

指示：如果得使用延长线，该延长线必须有接地安全引线（如同安全规章上的规定）。该安全引线可以透过插头和您的电动设备的安全引线联结。

如有任何疑问可以向合格的电工或博世的服务人员询问。



**小心：使用了不合格的延长线可能发生危险。只能使用能够防水，适合户外使用的延长线、插头和联结装置。**

连接好的电线必须保持干燥，不可以放置在地板上。

为了确保工作安全，必须使用最多 30 mA 额定剩余电流的漏电断路器（RCD）。每次使用前都得检查该漏电断路器。

如果电线受损了，只能把电线送给博世授权的维修厂修理。

针对 **非在英国** 贩卖的产品的指示：**注意：**为了您的安全，必须在机器的插头上连接延长线。延长线上的联结装置必须能够防水（水花）、由橡胶制成的或安装了橡胶套。延长线上必须配备塞绳扣。

请注意，本机器不可以无水的情况下运转。

## 正式操作

### 开动

把水管（不包含在供货范围中）连接在水管接头和机器上。

确定电源开关是设定在“0”的位置并且把机器连接在插座上。

打开水龍頭。

按下安全锁（喷射枪手柄上的后端开关）以便解除扳机的锁定。将扳机按到底直到水流均匀并且机器和高压软管中没有空气为止。放开扳机。按下安全锁（喷射枪手柄上的前端开关）。

打开电源开关。将喷射枪朝下。按下安全锁以便释放扳机。把扳机扣动到底。

### 自动关机功能

只要喷射枪手柄上的扳机被放开了，机器就会关闭马达。

## 有关操作方式的指点

### 一般通则

确定高压清洁机是放置在平坦的地面上。

不可以提着高压软管走得太前面，或者说不可以使用软管来拉动高压清洁机。这样可能导致高压清洁机摇晃并且翻倒。

不可以弯折高压软管，也不可以让车辆碾压高压软管。保护高压软管免被锋利的边缘或尖锐的凸角割损。

▶ 不可以使用旋转喷头和线状水柱清洗车辆。

**警告！**“Patio Cleaner”仅适合在平坦的表面使用！不可以用它清洗楼梯。勿碰触使用中的旋转喷头！

### 有关使用清洁剂时的操作指示

▶ **只能使用经过推荐并且适合高压清洁机的清洁剂。**

基于环保的理念，必须节约使用清洁剂。请注意清洁剂容器上所标示的有关稀释清洁剂的建议说明。

本产品随附的高压泡沫喷嘴，配备了调节清洁剂的开关。您可以根据需要调整清洁剂的排量。

### 建议的清洁方法

**第 1 步：**安装扁状喷嘴并粗步去除污垢。

**第 2 步：**装入洗涤剂瓶并涂抹少量的清洁剂。

**第 3 步：**使用扁状喷嘴冲洗被溶解的污垢和清洁剂。

**指示：**清洁竖立的平面时，先以清洁剂由下往上清洗。接着再从上端朝下冲洗。

### 使用替代水源

本自吸式高压清洁机，能够从水箱或天然的水源吸水。

**重要的是，**得在水的入口安装博世过滤器并确保过滤器清洁。只能吸汲干净的水。

### 开放式水箱 / 容器和天然水域

使用自吸配件，它是由以下部件组成：

- 吸汲滤网有逆止阀
- 3 米增强软管
- 高压清洁机的通用联结器

使用这个配件，高压清洁机能将水吸到水平面上方 0.5 米高处。这个过程可能需要约 15 秒。

将 3 米软管完全浸在水中，以便排除空气。把 3 米长的软管连接到高压清洁机上，并确保吸汲滤网仍然在水中。

让已经拆下喷射枪的高压清洁机持续运作，直至从高压清洁机流出的水稳定且均匀为止。如果过了 25 秒，仍然不见水流出来，则要关闭机器并检查所有的接头。如果水顺利流出，先关闭高压清洁机，接着再装上喷射枪和枪管便可以开始工作了。

软管和联结器的品质非常重要，另外软管和联结器务必要紧密结合，密封件不可以有毁损，而且要将软管垂直的插入联结器中。如果连接不紧密会影响吸力。

### 配备出水龙头的水箱

如果将高压清洁机连接在有出水龙头的水箱上，必须先要将软管（不包含在供货范围中）装在龙头上，并打开龙头以便排出软管中的空气，然后再把软管连接到高压清洁机上。



## 寻找故障的原因

症状	可能的原因	补救方法
马达无法启动	未插上插头	插好插头
	插头故障了	使用完好的插头
	保修丝断了	更换保险丝
	延长线故障了	拿掉延长线再试一次
	马达防护功能被启动了	让马达冷却约 15 分钟
	结冰了	让泵、水管及配件解冻
马达停止转动	保修丝断了	更换保险丝
	电压不符	检查电压，电压必须和机器铭牌上的规定一致
	马达防护功能被启动了	让马达冷却约 15 分钟
保险丝断了	保险丝太弱	把机器连接在别的电源系统，该系统的保险丝必须能够承担 高压清洁机的功率
马达继续运转，但是没有压力	喷嘴有一部分被堵塞了	清洁喷嘴
马达发出声音但是不运作	电压不足	检查电源的电压是否和机器铭牌上的规定一致
	因为使用延长线导致电压太低	检查所使用的延长线是否是合适的
	长期未使用机器	请向授权的博世顾客服务处求助
	自动停止功能出现问题	请向授权的博世顾客服务处求助
压力不均匀	水管中或泵中有空气	打开喷射枪和水龙头，将喷嘴调整到低压位置并让高压清洁机不断运转至恢复到均匀的工作压力为止
	水源供应不正常	检查水管的规格是否符合技术数据上的要求。允许使用的最小水管是 1/2 英寸或直径 13 毫米的水管
	滤网堵塞了	清洁滤网
	水管被压住或弯折了	摆好水管
	高压软管太长	拆下高压软管 - 延长件，最大的水管长度是 7 米
	喷嘴磨损了	更换喷嘴
	起 / 停阀磨损了	连续 5 次快速地按下板机
压力均匀但是太弱 指示：特定的配件会造成低压	未连接水源	连接好水源
	滤网阻塞了	清洁滤网
	喷嘴阻塞了	清洁喷嘴
高压清洁机自动启动	泵或喷射枪不紧密	请向授权的博世顾客服务处求助
机器漏水	泵不紧密	微量漏水是可容许的，如果漏水量加大得接洽顾客服务中心

## 维修和服务

### 维修

- ▶ 在机器上进行任何维护、修理的工作之前必须先拔出插头和连接水管。

**指示：** 定期执行以下的维修工作，以延长机器的使用寿命并确保操作安全。

定期检查机器是否有明显的故障，例如松脱的固定零件和磨损的机件等。

检查盖子和防护罩是否完好，安装方式是否正确。必要时得在使用机器前执行维护或修理的工作。

如果必须更换连接线，务必把这项工作交给博世或者经授权的博世电动工具顾客服务执行，以避免危害机器的安全性能。

### 使用完毕后 / 收藏

关闭起停开关并扣动扳机来排空高压软管。

使用软刷和布清洁高压清洁机的外壳。切勿使用水、稀释剂和抛光剂清洁机器。去除所有的污垢，尤其得清洁马达的通气缝隙。

季末储存机器时：放出泵中所有的水，此时要让马达运行数秒并扣动扳机。

不可以把其它的物品放置在机器上。

## 18 | 中文

把机器存放在无霜的环境中。  
要确定储存时电线不会被夹住。勿折弯高压软管。

**顾客服务处和顾客咨询中心**

[www.bosch-do-it.com](http://www.bosch-do-it.com)

查询和购买备件时，务必提供机器铭牌上标示的 10 位  
数物品代码。

有关保证，维修或更换零件事宜，请向合格的经销商查  
询。

**中国大陆**

博世电动工具（中国）有限公司  
中国 浙江省 杭州市  
滨江区滨康路 567 号  
邮政编码：310052  
免费服务热线：4008268484  
传真：(0571) 87774502  
电邮：[contact.ptcn@cn.bosch.com](mailto:contact.ptcn@cn.bosch.com)  
[www.bosch-pt.com.cn](http://www.bosch-pt.com.cn)

罗伯特·博世有限公司  
香港北角英皇道 625 号 21 楼  
客户服务热线：+852 2101 0235  
传真：+852 2590 9762  
电邮：[info@hk.bosch.com](mailto:info@hk.bosch.com)  
网站：[www.bosch-pt.com.hk](http://www.bosch-pt.com.hk)

**制造商地址：**

Robert Bosch Power Tools GmbH  
罗伯特·博世电动工具有限公司  
70538 Stuttgart / GERMANY  
70538 斯图加特 / 德国

**环保须知**

不可以让有害生态环境的化学物品残留在地面、地下  
水、池塘和河流中。

使用清洁剂时，务必详阅包装上的使用说明，以及注  
意规定的使用浓度。

清洗车辆时，必须兼顾贵国的有关法规：避免让冲刷下  
来的油垢流入地下水。

**处理废弃物**

必须以符合环保要求的方式回收再利用高压清洗机、配  
件和包装材料。

不可以将高压清洗机丢入一般的家庭垃圾中！

**只针对欧盟国家：**

根据针对废旧电器和电子设备的欧洲法  
规 2012/19/EU 以及被纳入国家法律来  
执行的相关规定：必须分开收集损坏的  
电气和电子用品，并以符合环保要求的  
方式回收再利用。

保留修改权。

**中文****安全規章****圖標說明**

一般性警告。



不可以把噴射出的水流  
朝向人、動物、機器或  
電動零件。

注意：如果使用不當，高壓水柱可  
能造成危險。



根據適用的法規，如果機器  
不具備系統分離功能，便不  
可以連接到飲用水的供應系  
統上。根據 IEC 61770，得使用  
BA 型的系統分離器。

流過系統分離器的水，已經不再是  
飲用水。



**AdvancedAquatak 150** 是針對  
每相線連接電流  $\geq 100$  安培，  
以及電壓為 230 伏特的電源  
所設計。如有供電方面的疑問，請  
聯系您當地的電力公司。

**高壓清潔機的安全規章**

閱讀所有的警告提示和指  
示。如未確實遵循警告提示  
和指示，可能導致電擊、火  
災並且 / 或其他的嚴重傷害。

機器上的警告和提示牌提供了重要  
的訊息，能夠確保操作安全。

除了遵循使用說明書上的指示之  
外，還必須兼顧一般性的安全規章  
和意外防範規定。

### 用電須知

- ▶ 電源的電壓必須和機器銘牌上提供的電壓一致。
- ▶ 最好將機器插在配備了 30 mA 剩餘電流保護開關的插座上。
- ▶ 即使您只是暫時離開機器，也要從插座上拔出插頭。
- ▶ 電源的電壓必須符合 IEC 60364-1 的要求。
- ▶ 如果需要更換電線，得由機器的製造商、經過製造商授權的客服中心或合格的專業人員執行此工作，以避免危害安全。
- ▶ 不可以使用潮濕的手拿插頭。
- ▶ 操作機器時不要拉扯插頭。
- ▶ 不可以輾過、壓過電線或延長線，也不可以拉扯它們。這樣會損壞電線。電線必須遠離高溫、油垢和鋒利的邊緣。
- ▶ 如果電線或重要的零件，例如高壓軟管、噴射槍或安全裝備等損壞了，便不可以使用機器。
- ▶ 注意：不符合規定的延長線可能造成危險。
- ▶ 使用延長線時，它的插頭和連接裝備都必須是防水的。延長線橫截面的尺寸必須符合使用說明書上的規定，延長線也要具備防水花的功能。插頭不可以浸泡在水中。
- ▶ 更換電線或延長線的插頭時，不可以破壞電線或延長線的防水安全性能和穩定性。

### 用水須知

- ▶ 請注意貴國供水單位的規定。
- ▶ 所有水管的接頭都不可以漏水。
- ▶ 只能使用直徑 12,7 毫米 (1/2") 的增強軟管。
- ▶ 把機器連接在飲用水源上時，務必在機器上安裝逆流閥。通過逆流閥的水則不適合飲用。
- ▶ 高壓軟管不能受損（有爆裂的危險）。高壓軟管如果損壞了必須馬上更換。只能使用製造商推薦的水管和連接件。
- ▶ 高壓軟管，節流裝備和連接裝備都攸關機器的安全性能。只能使用機器製造廠商推薦的軟管，節流裝備和連接裝備。
- ▶ 水源接頭只能連接乾淨或經過過濾的水。

### 使用須知

- ▶ 正式操作之前，先檢查機器和附件是否一切正常，是否會危害操作安全。如果發現任何故障則不可以使用機器。
- ▶ 不可以使用水流清洗自己的或別人的衣服、鞋子。
- ▶ 不可以吸汲含有溶解劑的液體、未稀釋的酸性液體、丙酮或溶解劑，例如汽油、顏料稀釋劑或柴油等。因為它們的噴霧極度易燃，容易爆炸並且有毒。
- ▶ 在危險的場所（例如加油站）使用本機器，務必遵守有關的安全規定。不可以有爆炸危險的場所使用本機器。

## 20 | 中文

- ▶ 機器必須放在平穩的地面上。
- ▶ 在密閉的空間使用本機器時要確保通風良好。並確定清潔過程中車輛處於熄火狀態（已經關閉馬達）。
- ▶ 必須用雙手操控高壓清潔機。不能在梯子上使用本機器。當在陽台或其他凸起的表面工作時，要確保隨時能看到所有的場地邊緣。
- ▶ 只能使用機器製造商推薦的清潔劑。並確實遵循機器製造商提出的使用說明、廢棄處理建議和警告提示。
- ▶ 做好工作場所中所有會導電零件的防水措施。
- ▶ 操作機器時，不可以讓噴射槍上的啟動開關，卡牢在 "ON" 的位置。
- ▶ 穿著能夠防水花的合適防護衣，如果在水流的噴射範圍內有旁人則不可以使用機器，除非他穿著了防護衣。
- ▶ 必要時得穿上合適的防護裝備（PSA）來防範噴濺的水花，例如佩戴護目鏡，防塵面具等來避開從物體上反彈的水，顆粒和 / 或氣溶膠。
- ▶ 高壓可能造成物體回彈。必要時，得穿上合適的個人防護裝備，例如護目鏡。
- ▶ 為了避免高壓水流造成傷害，清潔汽車輪胎和閥門時至少要保持 30 公分的距離。如果輪胎受損了，首先會出現輪胎變色的情形。受損的輪胎 / 閥門都可能造成生命危險。
- ▶ 不可以噴洗含石棉和其它含有毒素的物體。
- ▶ 經推薦的清潔劑必須先稀釋了再使用。這些產品是安全，因為它們不含酸、鹼或 其它有害環境的物質。我們建議您把清潔劑，存放在兒童無法取得之處。清潔劑如果接觸眼睛，必須馬上用水徹底清洗。誤食清潔劑必須馬上就醫。
- ▶ 使用高壓清潔機時務必安裝濾網，勿使用肮髒的或已經損壞的濾網。如果使用高壓清潔機時未安裝濾網，或是用了肮髒的、已經損壞的濾網，將導致保修失效。
- ▶ 長時間使用後，金屬零件可能變燙。如果必要的話得戴上防護手套。
- ▶ 不要在惡劣的天氣條件下特別是在雷雨來臨時，操作高壓清潔機。

## 操作須知

- ▶ 操作者務必按照規定使用機器。並且要注意操作現場的實際狀況。工作時務必顧慮到旁人，尤其是兒童。
- ▶ 只有經過操作指導的人或可以證明能夠操作本機器的人，才可以使用它。兒童或青少年不可以使用本機器。
- ▶ 不允許兒童，生理、感官或經神能力受限的人，經驗不夠和 / 或知識不足和 / 或不熟悉本指示的人操作本庭園工具。您本國的法規可能也會限制使用者的年齡。
- ▶ 看顧好小孩，以確保他們不會玩弄本庭園工具。
- ▶ 開動機器後，絕對不可以棄機器於不顧。
- ▶ 透過高壓噴射出的水柱可能造成危險。因此要用雙手握牢噴射槍和槍體。
- ▶ 不可以使用旋轉噴頭和線狀水柱清洗車輛。

## 搬運

- ▶ 搬運之前必須先關閉機器並固定好機器。

## 維修







- ▶ 清潔、維修機器和更換附件之前，都要先關閉機器。如果機器連接在插座上則要拔出插頭。
- ▶ 維修的工作只能交給博世授權的維修工廠執行。

## 附件和備件

- ▶ 只能使用製造廠商規定的附件和備件。使用原廠的附件和原廠的備件才能夠確保機器的正常功能。

## 代表符號

以下的符號可以幫助您正確地使用本機器。請詳細閱讀各符號及它們的代表意思。正確了解各符號所代表的意義，可以幫助您更有把握更安全地操作本機器。

符號	含義
	移動方向
	反應方向
	重量
	開啟
	關閉
Lo	較低的壓力
Hi	較高的壓力
	附件

## 按照規定使用機器

本機器可以清洗戶外的地面和物體，安裝了合適的附件及經過博世認可的清潔劑後，也能夠使用本工具清洗機器，車輛和船。

合適的操作環境溫度位在攝氏 0 ° C 和 40 ° C 之間。本產品不適合從事工業用途。

## 22 | 中文

## 技術性數據

高壓清潔機		AdvancedAquatak 150	AdvancedAquatak 160
物品代碼		3 600 HA7 7..	3 600 HA7 8..
額定輸入功率	kW	2,2	2,6
進口溫度最大	° C	40	40
進口水流最小	公升 / 每分	8	9,5
許可壓力	MPa	15	16
額定壓力	MPa	11	12
流量	公升 / 每分	7,5	8,5
最大進口壓力	MPa	1	1
自動關機功能		●	●
重量符合 EPTA-Procedure 01:2014	公斤	21,1	23,4
絕緣等級		⊕ / I	⊕ / I
序列號碼		參考序列號碼 (型號銘牌) 在高壓清潔機上	

本說明書提供的參數是以 230 伏特為依據，於低電壓地區，此數據有可能不同。

開動電動工具時，電壓會突然下降。如果電源網絡狀況不佳，可能會干擾其它機器。在電源阻抗小於 0,276 歐姆時不會產生干擾。如有疑問，請聯系您當地的電力公司。

## 安裝和操作

執行目的	圖片	頁數
供貨範圍	1	59
調節手柄	2	60
連接高壓軟管 / 噴射槍	3	60
連接水源	4	61
開動 / 關閉	5 - 6	61
清潔濾網	7	62
清潔噴嘴	8	62
將槍管連接在噴射槍上	9	62
插上噴嘴	10	63
連接洗滌劑罐	11	63
帶可變扇形射束的噴槍		
將槍管連接在噴射槍上		
調整噴嘴的水柱	12	64
帶旋轉射束的噴槍		
將槍管連接在噴射槍上		
調整噴嘴的水柱	13	65
儲放噴射槍	14	66
儲存	15	66
搬運	16	67
選擇附件	17	68

## 操作

## 針對您的安全



**注意！** 維修或清潔機器之前，先關閉機器並從插座上拔出插頭。如果電線受損、被割壞或纏繞在一起也要執行以上的防範措施。

工作電壓是 230 V AC, 50 Hz (針對非歐盟國家 220 V, 240 V 視機型而定)。只能使用經過許可的延長線，有關信息請聯系授權的顧客服務中心。

操作本高壓清潔機時，如果必須使用延長線，該延長線的截面積必須符合以下的規定：

– 2,5 毫米<sup>2</sup> 到最大 25 米長

指示：如果得使用延長線，該延長線必須有接地安全引線（如同安全規章上的規定）。該安全引線可以透過插頭和您的電動設備的安全引線聯結。

如有任何疑問可以向合格的電工或博世的服務人員詢問。



**小心：使用了不合格的延長線可能發生危險。只能使用能夠防水，適合戶外使用的延長線、插頭和聯結裝置。**

連接好的電線必須保持乾燥，不可以放置在地板上。

為了確保工作安全，必須使用最多 30 mA 額定剩餘電流的漏電斷路器 (RCD)。每次使用前都得檢查該漏電斷路器。

如果電線受損了，只能把電線送給博世授權的維修廠修理。

針對非在英國販賣的產品的指示：

**注意：**為了您的安全，必須在機器的插頭上連接延長線。延長線上的聯結裝置必須能夠防水（水花）、由橡膠制成的或安裝了橡膠套。延長線上必須配備塞繩扣。

請注意，本機器不能在無水的情況下運轉。

## 正式操作

## 開動

把水管（不包含在供貨範圍中）連接在水管接頭和機器上。

確定電源開關是設定在 "0" 的位置並且把機器連接在插座上。

打開水龍頭。

按下安全鎖（噴射槍手柄上的後端開關）以便解除扳機的鎖定。將扳機按到底直到水流均勻並且機器和高壓軟管中沒有空氣為止。放開扳機。按下安全鎖（噴射槍手柄上的前端開關）。

打開電源開關。將噴射槍朝下。按下安全鎖以便釋放扳機。把扳機扣動到底。

### 自動關機功能

只要噴射槍手柄上的扳機被放開了，機器就會關閉馬達。

## 有關操作方式的指點

### 一般通則

確定高壓清潔機是放置在平坦的地面上。

不可以提著高壓軟管走得太前面，或者說不可以使用軟管來拉動高壓清潔機。這樣可能導致高壓清潔機搖晃並且翻倒。

不可以彎折高壓軟管，也不可以讓車輛壓輾高壓軟管。保護高壓軟管免被鋒利的邊緣或尖銳的凸角割損。

▶ 不可以使用旋轉噴頭和線狀水柱清洗車輛。

**警告！** "Patio Cleaner" 僅適合在平坦的表面使用！不可以用它清洗樓梯。勿碰觸使用中的旋轉噴頭！

### 有關使用清潔劑時的操作指示

▶ 只能使用經過推薦並且適合高壓清潔機的清潔劑。

基於環保的理念，必須節約使用清潔劑。請注意清潔劑容器上所標示的有關稀釋清潔劑的建議說明。

本產品隨附的高壓泡沫噴嘴，配備了調節清潔劑的開關。您可以根據需要調整清潔劑的排量。

### 建議的清潔方法

**第 1 步：** 安裝扁狀噴嘴並粗步去除污垢。

**第 2 步：** 裝入洗滌劑瓶並塗抹少量的清潔劑。

**第 3 步：** 使用扁狀噴嘴沖洗被溶解的污垢和清潔劑。

**指示：** 清潔豎立的平面時，先以清潔劑由下往上清洗。接著再從上端朝下沖洗。

### 使用替代水源

本自吸式高壓清潔機，能夠從水箱或天然的水源吸水。**重要的是**，得在水的入口安裝博世過濾器並要確保過濾器清潔。只能吸汲干淨的水。

### 開放式水箱 / 容器和天然水域

使用自吸配件，它是由以下部件組成：

- 吸口濾網有逆止閥
- 3 米增強軟管
- 高壓清潔機的通用聯結器

使用這個配件，高壓清潔機能將水吸到水平面上方 0,5 米高處。這個過程可能需要約 15 秒。

將 3 米軟管完全浸在水中，以便排除空氣。把 3 米長的軟管連接到高壓清潔機上，並確保吸口濾網仍然位在水中。

讓已經拆下噴射槍的高壓清潔機持續運作，直至從高壓清潔機流出的水穩定且均勻為止。如果過了 25 秒，仍然不見水流出來，則要關閉機器並檢查所有的接頭。如果水順利流出，先關閉高壓清潔機，接著再裝上噴射槍和槍管便可以開始工作了。

軟管和聯結器的品質非常重要，另外軟管和聯結器務必要緊密結合，密封件不可以有毀損，而且要將軟管垂直的插入聯結器中。如果連接不緊密會影響吸力。

### 配備排水龍頭的水箱

如果將高壓清潔機連接在有出水龍頭的水箱上，必須先將軟管（不包含在供貨範圍中）裝在龍頭上，並打開龍頭以便排出軟管中的空氣，然後再把軟管連接到高壓清潔機上。

## 尋找故障的原因

症狀	可能的原因	補救方法
馬達無法起動	未插上插頭	插好插頭
	插座故障了	使用其它的插座
	保修絲斷了	更換保險絲
	延長線故障了	拿掉延長線再試一次
	馬達防護功能被啟動了	讓馬達冷卻約 15 分鐘
馬達停止轉動	結冰了	讓泵、水管或配件解凍
	保修絲斷了	更換保險絲
	電壓不符	檢查電壓，電壓必須和機器銘牌上的規定一致
	馬達防護功能被啟動了	讓馬達冷卻約 15 分鐘

## 24 | 中文

症狀	可能的原因	補救方法
保險絲斷了	保險絲太弱	把機器連接在別的電源系統，該系統的保險絲必須能夠承擔高壓清潔機的功率
馬達繼續運轉，但是沒有壓力	噴嘴有一部分被堵塞了	清潔噴嘴
馬達發出聲音但是不運作	電壓不足	檢查電源的電壓是否和機器銘牌上的規定一致
	因為使用延長線導致電壓太低	檢查所使用的延長線是否是合適的
	長期未使用機器	請向授權的博世顧客服務處求助
	自動停止功能出現問題	請向授權的博世顧客服務處求助
壓力不均勻	水管中或泵中有空氣	打開噴射槍和水龍頭，將噴嘴調整到低壓位置並讓高壓清潔機不斷運轉至恢復到均勻的工作壓力為止
	水源供應不正常	檢查水管的規格是否符合技術數據上的要求。允許使用的最小水管是 1/2 英寸或直徑 13 毫米的水管
	濾網堵塞了	清潔濾網
	水管被壓住或彎折了	擺好水管
	高壓軟管太長	拆下高壓軟管 - 延長件，最大的水管長度是 7 米
壓力均勻但是太弱	噴嘴磨損了	更換噴嘴
指示：特定的配件會造成低壓	起 / 停閥磨損了	連續 5 次快速地按下板機
馬達在運轉，但是壓力受限，或是無操作壓力	未連接水源	連接好水源
	濾網阻塞了	清潔濾網
	噴嘴阻塞了	清潔噴嘴
高壓清潔機自動起動	泵或噴射槍不緊密	請向授權的博世顧客服務處求助
機器漏水	泵不緊密	微量漏水是可容許的，如果漏水量加大得接洽顧客服務中心

## 維修和服務

### 維修

- ▶ 在機器上進行任何維護、修理的工作之前必須先拔出插頭和連接水管。

**指示：** 定期執行以下的維修工作，以延長機器的使用壽命和確保操作安全。

定期檢查機器是否有明顯的故障，例如鬆脫的固定零件和磨損的機件等。

檢查蓋子和防護罩是否完好，安裝方式是否正確。必要時得在使用機器前執行維護或修理的工作。

如果必須更換連接線，務必把這項工作交給博世或經授權的博世電動工具顧客服務執行，以避免危害機器的安全性能。

### 使用完畢後 / 收藏

關閉起停開關並扣動扳機來排空高壓軟管。

使用軟刷和布清潔高壓清潔機的外殼。切勿使用水、稀釋劑和拋光劑清潔機器。去除所有的污垢，尤其得清潔馬達的通氣縫隙。

季末儲存機器時：放出泵中所有的水，此時要讓馬達運行數秒並扣動扳機。

不可以把其它的物品放置在機器上。

把機器存放在無霜的環境中。

要確定儲存時電線不會被夾住。勿折彎高壓軟管。

### 顧客服務處和顧客諮詢中心

[www.bosch-do-it.com](http://www.bosch-do-it.com)

查詢和購買備件時，務必提供機器銘牌上標示的 10 位數物品代碼。

#### 台灣

台灣羅伯特博世股份有限公司

建國北路一段 90 號 6 樓

台北市 10491

電話：(02) 2515 5388

傳真：(02) 2516 1176

[www.bosch-pt.com.tw](http://www.bosch-pt.com.tw)

#### 制造商地址：

Robert Bosch Power Tools GmbH

羅伯特·博世電動工具有限公司

70538 Stuttgart / GERMANY

70538 斯圖加特 / 德國



### 환경부지

不可以讓有害生態環境的化學物品殘留在地面、地下水、池塘和河流中。

使用清潔劑時，務必詳閱包裝上的使用說明，以及注意規定的使用濃度。

清洗車輛時，必須兼顧貴國的有關法規：避免讓沖刷下來的油垢流入地下水。

### 處理廢棄物

必須以符合環保要求的方式回收再利用高壓清潔機、配件和包裝材料。

不可以將高壓清潔機丟入一般的家庭垃圾中！

**只針對歐盟國家：**



根據針對廢舊電器和電子設備的歐洲法規 2012/19/EU 以及被納入國家法律來執行的相關規定；必須分開收集壞損的電氣和電子用品，並以符合環保要求的方式回收再利用。

保留修改權。



**AdvancedAquatak 150** 는 전류 용량이 위상 당 100A 이상이고 정격 전압이 230V 인 전원에 연결하여 사용해야 합니다. 확실하지 않으면 귀하의 전원 공급사에 문의하십시오.

### 고압 세척기용 안전수칙



**모든 안전수칙과 지시 사항을 상세히 읽고 지켜야 합니다.** 다음의 안전수칙과 지시 사항을 준수하지 않으면 화재 위험이 있으며 감전 혹은 중상을 입을 수 있습니다.

**기기에 붙어있는 경고 및 지시 사항은 안전한 작동을 위한 중요한 내용입니다.**

**사용 설명서에 나와 있는 내용 이외에도 일반 안전규정과 사고방지 조치를 준수해야 합니다.**

## 한국어

### 안전 수칙

#### 기호 설명



일반적인 위험 경고.



사람이나 동물 혹은 기기 본체 및 전기 부품에 물을 분사하지 마십시오.

주의: 고압 분사를 잘못 사용하면 위험할 수 있습니다.



**해당 규정에 따르면 시스템 분리가 없는 기기를 식수망에 연결해서는 안됩니다. IEC 61770 Typ BA 에 따라 시스템 분리를 사용하십시오.**

**시스템 분리를 통과한 물을 식수로 사용해서는 안됩니다.**

### 전원에 연결하기

- ▶전원의 전압이 기기 명판에 표기된 전압과 일치해야 합니다.
- ▶기기를 30 mA 누전 차단기가 있는 전원 콘센트에만 연결하는 것이 좋습니다.
- ▶잠시라도 기기를 두고 자리를 비울 경우 전원 콘센트에서 플러그를 빼십시오.
- ▶전원 공급은 IEC 60364-1 에 부응해야 합니다.
- ▶연결 코드를 교체해야 할 경우 안전사고를 방지하기 위해 제조사나 제조사가 지정한 서비스 센터 혹은 이를 실행할 수 있는 전문 기사에게 맡기십시오.

## 26 | 한국어

- ▶ 절대로 전원 플러그를 젖은 손으로 만지지 마십시오.
- ▶ 기기로 작업하는 도중에 전원 플러그를 당기지 마십시오.
- ▶ 전원 코드나 연장 케이블이 손상될 수 있으므로 차량에 밟이지 않도록 하고 조이거나 잡아당기지 마십시오. 케이블을 고열에 두지 말고 오일 혹은 날카로운 모서리에 접하지 않도록 하십시오.
- ▶ 전원 코드나 고압 호스, 분사 건, 안전장치 등 주요 부품이 손상된 경우 기기를 사용하지 마십시오.
- ▶ 주의: 규정에 맞지 않는 연장 케이블은 위험할 수 있습니다.
- ▶ 연장 케이블을 사용할 경우 플러그와 연결장치는 방수제품이어야 합니다. 연장 케이블의 직경은 사용 설명서에 나온 크기로 분사하는 물에 안전해야 합니다. 플러그 연결 부위가 물에 들어가지 않도록 하십시오.
- ▶ 전원 연결 코드나 연장 케이블의 플러그를 교환할 경우 물 분사에 안전하고 기계적인 안전성을 유지해야 합니다.

**급수전에 연결하기**

- ▶ 귀하의 급수 회사 규정을 준수하십시오.
- ▶ 모든 연결 호스의 연결장치가 밀폐되어 있어야 합니다.
- ▶ 반드시 직경 12.7 mm (1/2") 인 보강된 호스만을 사용하십시오.
- ▶ 절대로 기기를 역류 밸브 없이 식수 공급원에 연결해서는 안 됩니다. 역류 밸브를 통과한 물은 식수로 사용할 수 없다고 간주됩니다.
- ▶ 고압 호스가 손상되서는 안됩니다 (파열 위험). 손상된 고압 호스는 즉시 교환해 주십시오. 제조사가 추천하는 호스와 연결장치만을 사용해야 합니다.
- ▶ 고압 호스, 부속품 그리고 연결장치는 기기의 안전을 위해 중요합니다. 그러므로 제조사가 추천하는 호스와 부속품 및 연결장치만을 사용하십시오.
- ▶ 급수 연결장치에는 깨끗하거나 여과된 물만을 사용해야 합니다.

**사용**

- ▶ 사용하기 전에 기기와 액세서리가 정상 상태인지 안전한 작동 여부를 점검하십시오. 하자가 있으면 기기를 사용하면 안됩니다.
- ▶ 옷이나 신발을 세척하기 위해 작업자 자신이나 다른 사람에게 분사하지 마십시오.
- ▶ 용제를 함유한 액체, 희석되지 않은 산, 아세톤 혹은 벤젠, 페인트 희석제, 난방유를 포함한 용제를 흡입해서는 안됩니다. 그 분무가 가연성이고 폭발성이며 독성이기 때문입니다.
- ▶ 주유소 등 위험한 분야에서 기기를 사용할 경우 이에 해당하는 안전수칙을 준수하십시오. 폭발 위험이 있는 곳에서는 사용이 금지되어 있습니다.
- ▶ 기기를 견고한 바닥 위에 놓아야 합니다.
- ▶ 밀폐된 공간에서 작업할 경우 충분히 환기해 주어야 합니다. 차량

- 을 세척하는 동안 모터가 꺼져 있는지 확인해 보십시오.
- ▶ 고압 세척기는 양손으로 사용해야 합니다. 사다리 위에서 작업하지 마십시오. 발코니나 기타 높은 표면에 작업할 때 모든 모서리가 보이는지 확인하십시오.
  - ▶ 반드시 기기 제조사가 추천하는 세제를 사용하고, 제조사의 사용 방법, 처리 및 경고 사항을 준수하십시오.
  - ▶ 작업장에 있는 전류가 통하는 모든 부품은 물 분사에 안전해야 합니다.
  - ▶ 작동할 때 분사 건 레버를 “ON” 위치로 고정해서는 안 됩니다.
  - ▶ 물분사로부터 보호하기 위해 적합한 안전 복장을 하십시오. 안전 복장을 착용하지 않은 사람이 가까이 있으면 기기를 사용하지 마십시오.
  - ▶ 사물에 반사되는 물이나 분자 혹은 에어로졸로부터 보호하기 위해 필요에 따라 보안경이나 분진 마스크 등 적합한 개인 보호구 (PPE) 를 착용하십시오.
  - ▶ 높은 수압으로 인해 물체가 튕겨 나갈 수 있으므로 필요에 따라 보안경 등 적합한 보호 장비를 착용하십시오.
  - ▶ 고압 분사로 인해 손상되는 것을 방지하기 위해 차량 타이어 / 밸브는 최소한 30 cm 간격을 유지하며 청소하십시오. 손상된 초기 증상은 타이어가 변색하는 것입니다. 손상된 차량 타이어 / 밸브는 매우 위험합니다.
  - ▶ 석면을 함유하거나 유해한 물질을 함유한 소재를 분사해서는 안 됩니다.
  - ▶ 추천하는 세제는 희석하여 사용해야 합니다. 제품에 산과 알칼리 혹은 환경에 유해한 물질이 함유되어 있지 않으므로 비교적 안전합니다. 세제는 어린이 손이 닿지 않는 곳에 보관하는 것이 좋습니다. 세제가 눈에 들어간 경우 즉시 물로 깨끗이 닦아내고, 삼켰을 경우 즉시 의사를 방문하십시오.
  - ▶ **고압 세척기는 항상 필터를 장착하여 사용하고, 오염되거나 손상된 필터는 사용하지 마십시오.** 필터 없이 혹은 오염되거나 손상된 필터와 함께 고압 세척기를 사용한 경우 품질보장을 받지 못합니다.
  - ▶ 장시간 사용하고 나면 금속 부품이 뜨거워질 수 있습니다. 필요에 따라 보호장갑을 착용하십시오.
  - ▶ 날씨가 좋지 않은 경우 특히 번개 위험이 있으면 고압 세척기를 사용하지 마십시오.
- ### 작동
- ▶ 작업자는 기기를 규정에 따른 사용 분야에만 사용해야 합니다. 현지 상황을 고려하십시오. 작업 시 주위에 어린이나 사람이 있는지 주의하십시오.
  - ▶ 본 기기는 사용법과 취급에 대한 교육을 받거나 기기를 작동할 수 있는 자격이 있는 사람만이 사용해야 합니다. 어린이나 청소년이 이 기기를 작동해서는 안 됩니다.

28 | 한국어

- ▶ 어린이나 신체적, 감각 기능 혹은 정신적 기능에 장애가 있는 사람, 혹은 경험과 지식이 부족하거나 사용법을 잘 모르는 사람이 절대로 이 기기를 사용하지 못하게 하십시오. 국내 규정에 따라 사용자 연령 제한이 있을 수 있습니다.
- ▶ 어린이가 정원용 공구를 갖고 놀지 않도록 감독하십시오.
- ▶ 기기의 스위치가 켜진 상태에서 절대로 자리를 비우면 안됩니다.
- ▶ 고압 노즐에서 나오는 물분사로 반동이 생기므로 분사 건과 분사 램스를 양손으로 꼭 잡으십시오.
- ▶ 차량을 세척할 때 절대로 로터리 노즐이나 스포트 분사를 사용해서는 안됩니다.

**운반**

- ▶ 운반하기 전에 기기의 스위치를 끄고 안전하게 하십시오.

**보수 정비**





- ▶ 각종 세척 및 보수작업을 하거나 액세서리를 교환하기 전에 반드시 기기의 스위치를 끄십시오. 기기를 배전 전압에 연결하여 작동할 경우 전원 플러그를 빼십시오.
- ▶ 수리는 반드시 보쉬 지정 서비스 센터에서만 실시하도록 말기하십시오.

**액세서리와 스페어 부품**

- ▶ 제조사가 허용하는 액세서리와 부품만을 사용하십시오. 정품 액세서리 및 부품을 사용해야 하자 없는 기기의 작동을 보장할 수 있습니다.

**기호**

다음에 나와있는 기호는 사용 설명서를 읽고 이해하는 데 중요합니다. 그러므로 기호와 그 의미를 잘 기억하십시오. 기호를 제대로 이해하면 전동공구를 더욱 쉽고 안전하게 사용할 수 있습니다.

기호	의미
	이동 방향
	반동 방향
	중량
	온
	오픈
Lo	저압
Hi	고압
	별매 액세서리

**규정에 따른 사용**

본 기기는 적합한 액세서리와 보쉬사가 허용하는 세제를 사용하여 실외에 있는 표면이나 물체, 기기, 차량 및 보트를 세척할 때 사용해야 합니다.

규정에 따른 사용은 주변 온도 0 °C에서 40 °C 사이의 경우입니다.

본 제품은 영업용으로 적합하지 않습니다.

## 제품 사양

고압 세척기	AdvancedAquatak 150	AdvancedAquatak 160	
제품 번호	3 600 HA7 7..	3 600 HA7 8..	
정격 출력	kW	2.2	2.6
최대 급수 온도	°C	40	40
분당 급수량	l/min	8	9.5
허용 압력	MPa	15	16
정격 압력	MPa	11	12
토출량	l/min	7.5	8.5
최대 급수 압력	MPa	1	1
자동 정지 기능		●	●
EPTA 공정 01:2014 에 따른 중량	kg	21.1	23.4
안전 등급		⊕ / I	⊕ / I
일련번호	고압 세척기에 있는 일련번호 (명판) 참조		

자료는 정격 전압 [U] 230 V 를 기준으로 한 것입니다. 전압이 낮거나 각국의 특수한 모델에 따라 달라질 수 있습니다.

돌입 전류는 단시간 전압 강하를 유발합니다. 전원 공급 조건이 좋지 않은 경우 다른 기기에 영향을 미칠 수 있습니다. 전원 공급 시스템 임피던스가 0.276 Ohm 이하인 경우 아무런 이상이 없습니다. 확실하지 않으면 귀하의 전원 공급사에 문의하십시오.

## 조립 및 작동

작업 내용	그림	페이지
공급 내역	1	59
손잡이 조절하기	2	60
고압 호스 / 분사 건 연결	3	60
급수전에 연결하기	4	61
전원 스위치 작동하기	5-6	61
필터 청소하기	7	62
노즐 청소하기	8	62
분사 건에 램스 연결하기	9	62
노즐 장착하기	10	63
세제 용기에 연결하기	11	63
다양한 팬 제트 램스		
분사 건에 램스 연결하기		
노즐 분사 조절하기	12	64
로터리 제트 램스		
분사 건에 램스 연결하기		
노즐 분사 조절하기	13	65
분사 건 보관하기	14	66
보관	15	66
운반	16	67
액세서리 선택하기	17	68

## 시동

### 작업 안전



**주의! 보수 및 정비작업을 하기 전에 기기의 스위치를 끄고 전원 플러그를 빼십시오. 전원 코드가 손상되거나 일부 절단되거나 꼬인 경우도 마찬가지입니다.**

작동 전압은 230 V AC, 50 Hz (EU 이외 국가의 경우 모델에 따라 220 V, 240 V) 입니다. 반드시 허용된 연장 케이블만을 사용하십시오. 이에 대한 정보는 지정 서비스 센터에 문의해 주십시오.

고압 세척기에 연장 케이블을 사용하여 작업하려면 다음의 케이블 직경이 필요합니다:

- 2.5mm<sup>2</sup> 최대 길이 25m

참고: 연장 케이블을 사용할 경우 안전 규정에 나온대로 접지되어 있어야 하며 귀하의 전기 설비 접지선이 플러그에 연결되어 있어야 합니다.

확실하지 않은 경우 전기 기사나 가까운 보쉬 서비스 센터에 문의하십시오.



**주의: 규정에 맞지 않는 연장 케이블은 위험할 수 있습니다. 연장 케이블, 플러그, 연결 장치는 방수제품으로 실외용 모델이어야 합니다.**

케이블 연결 부위가 건조해야 하며 바닥에 놓이지 않도록 하십시오.

안전을 기하기 위해 잔류 전류가 최대 30 mA 인 누전 차단기 (RCD) 를 사용하십시오. 사용하기 전에 매번 누전 차단기를 점검하십시오.

연결 케이블이 손상된 경우 반드시 보쉬 지정 서비스 센터에 맡겨 수리해야 합니다.

**영국 이외의 국가에서 판매되는 제품을 위한 참고 내용:**  
**주의:** 귀하의 안전을 위해 기기에 달린 플러그가 연장 케이블에 연결되어야 합니다. 연장 케이블의 연결장치는 물 분사에 안전해야 하며, 고무로 되어있거나 고무가 씌워져 있어야 합니다. 연장 케이블은 변형 완화 특성이 있어야 합니다.

본 제품은 반드시 물을 사용하여 작동해야 합니다.

## 30 | 한국어

**작동****스위치 켜기**

물호스 (별매품)로 급수 연결장치와 기기를 연결하십시오.

전력 본선 스위치가 "0" 위치에 있는 상태에서 기기를 전원 콘센트에 연결해야 합니다.

수도꼭지를 엽니다.

방아쇠를 풀기 위해 시동 안전 잠금장치 (건 손잡이의 뒤쪽 스위치)를 누르십시오. 물이 일정하게 흐르고 기기와 고압 호스 안에 있는 공기가 완전히 빠질 때까지 방아쇠를 끝까지 누르십시오. 방아쇠를 놓으십시오. 시동 안전 잠금장치 (건 손잡이의 앞쪽 스위치)를 누르십시오. 전원 스위치를 돌리고 분사 건을 아래로 향하게 하십시오. 방아쇠를 풀기 위해 시동 안전 잠금장치를 누르십시오. 방아쇠를 완전히 끝까지 누르십시오.

**자동 정지 기능**

피스톤 손잡이의 방아쇠를 놓으면 기기가 자동으로 정지됩니다.

**사용방법****일반**

고압 세척기가 평평한 바닥에 놓여 있는지 확인하십시오.

고압 호스를 들고 너무 앞으로 가거나 호스를 잡고 고압 세척기를 당기지 마십시오. 이 경우 고압 세척기가 불안정하게 되어 쓰러질 수 있습니다.

고압 호스를 꺾지 말고 차량에 밟히지 않도록 하십시오. 고압 호스가 날카로운 모서리나 구석에 닿지 않도록 하십시오.

▶ 차량을 세척할 때 절대로 로터리 노즐이나 스포트 분사를 사용해서는 안됩니다.

**경고!** "Patio Cleaner"를 평평한 표면에서만 사용해야 합니다! 계단에 사용하지 마십시오. 로터리 노즐이 작동 중일 때 절대로 이를 만지지 마십시오!

**세제 사용 시 사용방법**

▶ **고압 세척기용으로 나온 세제만을 사용하십시오.**

환경보호를 위해 소량의 세제를 사용하는 것이 좋습니다. 용기에 표기된 희석에 관한 추천 내용을 준수하십시오. 이 제품과 함께 공급되는 고압 폼 노즐에는 세제 조정장치가 있어 필요에 따라 조절됩니다.

**추천하는 청소방법**

**1 단계:** 팬 제트 노즐을 조립하고 이를 사용하여 더러운 부위를 대강 제거하십시오.

**2 단계:** 세제 용기를 조립하고 이를 사용하여 약간의 세제를 바르십시오.

**3 단계:** 분리된 더러운 부위와 세제를 팬 제트 노즐을 사용하여 씻어내십시오.

**주의:** 세제를 사용하여 수직면에 세척할 때 아래서부터 시작하여 위로 작업하십시오. 씻어낼 때는 위에서 아래로 작업하십시오.

**대체적인 급수원에 연결하여 사용**

본 고압 세척기는 물탱크나 천연 수원에서 물을 자동으로 흡입합니다. 그러므로 항상 깨끗한 물을 사용하고 급수 부위에 있는 보쉬 필터를 세척하여 장착하는 것이 **중요합니다**.

**열린 물탱크와 천연수**

다음 액세서리로 구성된 자흡식 장치를 사용하십시오:

- 역류 방지 밸브가 있는 흡입 필터
- 강화된 3 m 흡입 호스
- 고압 세척기용 유니버설 커플링

이 액세서리를 사용하면 고압 세척기로 수면 위 0.5 m 까지 물을 흡입할 수 있으며 이는 15 초 가장 걸릴 수 있습니다.

공기를 빼기 위해 3 m 호스를 완전히 물 안에 넣으십시오. 그리고 나서 3 m 흡입 호스를 고압 세척기에 연결하고, 이때 흡입 필터가 계속 물 안에 있도록 해야 합니다.

물이 고압 호스에서 일정하게 나올 때까지 분사 건을 분리한 상태로 고압 세척기를 작동하십시오. 25 초가 지나도 물이 나오지 않으면 스위치를 끄고 모든 연결 부위를 확인해 보십시오. 물이 나오면 고압 세척기를 끄고, 작업을 위해 분사 건과 분사 렌스를 연결하십시오.

좋은 품질의 호스와 커플링이 제대로 연결되어 있어야 하며, 손상되지 않은 실링이 바르게 끼워져 있는 것이 중요합니다. 연결장치가 완전히 밀폐되어 있지 않으면 자동 흡입에 지장을 줄 수 있습니다.

**배수 꼭지가 있는 물탱크**

고압 세척기를 적합한 배수 꼭지가 있는 물탱크에 연결해야 할 경우 우선 물 호스 (함께 공급되지 않음)를 물탱크 꼭지에 연결해야 합니다. 꼭지를 열고 호스 안에 있는 공기를 모두 빼내고 나서 고압 세척기에 연결하십시오.

## 고장 원인찾기

증상	가능한 원인	조치
모터가 작동하지 않습니다	전원 플러그가 연결되지 않았습니까 콘센트가 고장입니다 퓨즈가 단선되었습니다 연장 케이블이 손상되었습니다 모터 보호장치가 작동하였습니다 동결되었습니다	전원 플러그를 연결하십시오 다른 콘센트를 사용하십시오 퓨즈를 교체하십시오 연장 케이블 없이 시도하십시오 모터를 15 분 동안 식하십시오 펌프, 호스 및 액세서리를 해동하십시오
모터가 정지됩니다	퓨즈가 단선되었습니다 배전 전압이 맞지 않습니다 모터 보호장치가 작동하였습니다	퓨즈를 교체하십시오 배전 전압이 기기 명판에 표기된 전압과 일치하는지 확인하십시오 모터를 15 분 동안 식하십시오
퓨즈가 단선됩니다	퓨즈가 너무 약합니다	고압 세척기의 성능에 맞게 안전장치가 되어 있는 전원에 연결하십시오
모터는 작동하지만 수압이 없습니다	노즐이 일부 막혔습니다	노즐 청소하기
모터 소리는 나는데 작동하지 않습니다	배전 전압이 부족합니다 연장 케이블을 사용하여 전압이 너무 낮습니다 기기를 너무 오랫동안 사용하지 않았습니다 자동정지 기능에 문제가 있습니다	전원의 전압이 기기 명판에 표기된 전압과 일치하는지 확인하십시오 연장 케이블이 적합한지 확인해 보십시오 보쉬 지정 서비스 센터에 문의하십시오
수압이 맥동합니다	호스나 펌프에 공기가 들어 있습니다 급수 상태가 적합하지 않습니다 필터가 막혔습니다 호스가 눌렀거나 꺾인 상태입니다 고압 호스가 너무 길입니다	일정한 작동 압력이 될 때까지 분사 건을 누르고 급수전을 연 채 저압 모드로 고압 세척기를 작동하십시오 급수 연결이 제품 사양에 나와 있는 내용과 부응하는지 확인하십시오. 사용 가능한 최소한 호스 크기는 1/2" 혹은 직경 13 mm 입니다 필터를 청소하십시오 호스를 일직선으로 놓으십시오 고압 호스 연장선을 빼십시오, 최대 호스 길이 7 m
수압이 일정하지만 너무 낮습니다	노즐이 마모되었습니다 참고 : 특정한 액세서리로 인해 수압이 낮아집니다	노즐을 교체하십시오 방아쇠를 짧은 간격으로 5 회 작동하십시오
모터는 작동하지만 수압이 한정되거나 작동 압력에 미달합니다	급수가 연결되지 않았습니다 필터가 막혔습니다 노즐이 막혔습니다	급수를 연결하십시오 필터 청소하기 노즐을 청소하십시오
고압 세척기가 자동으로 시동합니다	펌프나 분사 건이 썩습니다	보쉬 지정 서비스 센터에 문의하십시오
기기가 썩니다	펌프가 썩니다	약간의 누수는 무방합니다; 누수가 심하면 서비스 센터에 문의하십시오

## 보수 정비 및 서비스

### 보수 정비

- ▶ 기기에 각종 보수 정비작업을 하기 전에 전원 플러그를 빼고 급수 연결장치를 풀어 주십시오.

**참고 :** 장기간 신뢰성 있는 사용을 보장하기 위해 다음의 보수 정비작업을 정기적으로 실시하십시오.

기기의 조임장치가 느슨하거나 부품이 마모 혹은 손상되지 않았는지 정기적으로 점검하십시오.

**32 | ภาษาไทย**

커버와 안전장치가 손상되지 않았는지 제대로 부착되어 있는지 확인하십시오. 사용하기 전에 필요한 보수 및 수리작업을 실시하십시오.  
연결 코드를 교환해야 할 경우 안전을 기하기 위해 보쉬 사나 보쉬 지정 전동공구 서비스 센터에 맡겨야 합니다.

**사용 후 관리 / 보관**

전원 스위치를 끄고 나서 고압 호스를 비우기 위해 방아쇠를 작동하십시오.  
고압 세척기 표면은 부드러운 솔이나 천으로 깨끗이 닦아 주십시오. 물, 용제 혹은 광택제를 사용하면 안됩니다. 더러운 부위를 모두 닦고, 특히 모터의 통풍구를 청소하십시오.  
시즌 후 보관: 모터를 몇 초간 작동하고 방아쇠를 당겨 펌프에서 물을 완전히 빼십시오.  
기기 위에 아무런 물건도 올려놓지 마십시오.  
기기를 서리가 없는 곳에서 보관하십시오.  
보관 시 케이블이 조여져 있지 않은지 확인해 보십시오.  
고압 호스가 꺾이지 않도록 하십시오.

**보쉬 AS 및 고객 상담**

[www.bosch-do-it.com](http://www.bosch-do-it.com)

문의 사항이 있거나 스페어 부품을 주문할 때 반드시 기기의 명판에 표기된 10 자리의 제품 번호를 알려 주십시오.

Bosch Korea, RBKR  
Mechanics and Electronics Ltd.  
PT/SAX-ASA  
298 Bojeong-dong Giheung-gu  
Yongin-si, Gyeonggi-do, 446-913  
Republic of Korea  
080-955-0909

**환경 보호**

환경에 유해한 화학물이 토지, 지하수, 연못이나 강으로 들어가서는 안 됩니다.  
세제를 사용할 경우 포장에 나온 내용과 규정된 농도를 정확히 준수하십시오.  
모터 차량을 세척할 경우 현지의 규정을 준수하십시오: 분사한 오일이 지하수 안으로 들어가지 않도록 해야 합니다.

**처리**

고압 세척기, 액세서리 및 포장 등은 환경 친화적인 방법으로 재활용 수 있도록 분류하십시오.  
고압 세척기를 가정용 쓰레기로 처리하지 마십시오!

**EU 국가만 해당 :**



폐전기전자제품처리에 관한 EU 지침 2012/19/EU 와 해당 국가법 이행에 따라 더 이상 사용이 불가능한 전기제품과 전자 제품은 분리 수거하여 환경 친화적인 방법으로 재활용하도록 해야 합니다.

위 사항은 사전 예고 없이 변경될 수도 있습니다.

**ภาษาไทย**

**กฎระเบียบเพื่อความปลอดภัย**

**คำอธิบายของสัญลักษณ์**



การเตือนอันตรายทั่วไป



อย่าเล็งลำน้ำที่ฉีดออกมาพุ่งตรงไปยังคน สัตว์ เครื่อง หรือชิ้นส่วนไฟฟ้าอย่างเด็ดขาด

คำเตือน: ลำน้ำฉีดแรงดันสูงอาจเป็นอันตรายได้หากใช้ในทางที่ผิด



ตามระเบียบที่ใช้บังคับ ต้องไม่เชื่อมต่อเครื่องเข้ากับเครือข่ายนำประปาดื่ม

โดยไม่มีอุปกรณ์แยกกระบบอย่างเด็ดขาด ใช้อุปกรณ์แยกกระบบตามมาตรฐานสากล IEC 61770 ประเภท BA

น้ำที่ไหลผ่านอุปกรณ์แยกกระบบถือว่าดื่มไม่ได้



AdvancedAquatak 150 มีไว้ใช้ในสถานที่ที่มีระบบจ่ายกำลังไฟฟ้า ≥100 แอมแปร์ต่อเฟส

และแรงดันไฟฟ้าระบบ 230 โวลต์ เท่านั้น หากมีข้อสงสัย กรุณาติดต่อการไฟฟ้าที่รับผิดชอบเรื่องการจ่ายกระแสไฟฟ้าของท่าน



## คำเตือนเพื่อความปลอดภัยสำหรับ เครื่องฉีดน้ำแรงดันสูง



### ต้องอ่านคำเตือนเพื่อความปลอดภัยและคำสั่งทั้งหมด

การไม่ปฏิบัติตามคำเตือนและคำสั่งอาจเป็นสาเหตุให้ถูกไฟฟ้าดูด เกิดไฟไหม้ และ/หรือได้รับบาดเจ็บอย่างร้ายแรง

**ป้ายเตือนและข้อมูลที่ติดมากับเครื่องให้ข้อมูลสำคัญเกี่ยวกับการทำงานอย่างปลอดภัย**

นอกจากข้อมูลในหนังสือคู่มือการใช้งานแล้ว ยังต้องปฏิบัติตามคำเตือนเพื่อความปลอดภัยทั่วไปและกฎระเบียบเพื่อการป้องกันการเกิดอุบัติเหตุด้วย

### การเชื่อมต่อกับแหล่งจ่ายกระแสไฟฟ้า

- ▶ แรงดันไฟฟ้าที่ระบุไว้บนแผ่นป้ายต้องสอดคล้องกับแรงดันไฟฟ้าของแหล่งจ่ายกระแสไฟฟ้า
- ▶ เราขอแนะนำให้เชื่อมต่อเครื่องนี้เข้ากับเต้าเสียบที่มีการป้องกันด้วยเครื่องตัดกระแสไฟฟ้าพิเศษเหลือขนาด 30 mA เท่านั้น
- ▶ ถอดปลั๊กไฟออกจากเต้าเสียบเมื่อใดก็ตามที่ท่านปล่อยเครื่องไว้โดยไม่ดูแลแม้ช่วงเวลาสั้นๆ
- ▶ การเชื่อมต่อไฟฟ้าต้องสอดคล้องกับมาตรฐานสากล IEC 60364-1
- ▶ หากสายไฟฟ้าชำรุด ต้องส่งเครื่องไปเปลี่ยนสายไฟฟ้าที่บริษัทผู้ผลิต ศูนย์บริการของบริษัท หรือบุคคลที่มี

คุณสมบัติใกล้เคียงกัน ทั้งนี้เพื่อหลีกเลี่ยงอันตราย

- ▶ อย่าสัมผัสปลั๊กไฟฟ้าด้วยมือเปียกๆ อย่างเด็ดขาด
- ▶ อย่าดึงปลั๊กไฟฟ้าในขณะที่กำลังใช้เครื่องทำงาน
- ▶ อย่าวิ่งทับ บีบอัด หรือดึงสายเคเบิลและสายไฟต่อพ่วง มิฉะนั้นอาจเสียหายได้ ปกป้องสายเคเบิลจากความร้อน น้ำมัน และขอบแหลมคม
- ▶ อย่าใช้เครื่องหากสายเคเบิลหรือชิ้นส่วนสำคัญ ต.ย. เช่น สายยางแรงดันสูง ปืนฉีด หรืออุปกรณ์ความปลอดภัยเสียหาย
- ▶ คำเตือน:  
สายไฟต่อพ่วงที่ไม่ตรงตามกฎระเบียบอาจเป็นอันตรายได้
- ▶ หากใช้สายไฟต่อพ่วงทำงาน ปลั๊กไฟฟ้า และเต้าเสียบจะต้องออกแบบให้กันน้ำได้ สายไฟต่อพ่วงต้องมีภาคตัดขวางตามหนังสือคู่มือการใช้งานและได้รับการปกป้องจากน้ำที่สะอาด กระเด็น ต้องไม่วางการเชื่อมต่อในน้ำ
- ▶ เมื่อเปลี่ยนปลั๊กไฟฟ้าที่สายเคเบิลหรือสายไฟต่อพ่วง การปกป้องน้ำสะอาดกระเด็นและความคงตัวของเครื่องมือกลจะต้องยังคงเหมือนเดิม

### การเชื่อมต่อกับน้ำ

- ▶ ปฏิบัติตามระเบียบข้อบังคับของบริษัทจัดส่งน้ำของท่าน
- ▶ สายยางเชื่อมต่อทั้งหมดต้องมีข้อต่อฉีกกันรั่วอย่างถูกต้อง
- ▶ ตรวจสอบให้แน่ใจว่าสายยางส่งน้ำมีขนาดเส้นผ่าศูนย์กลางอย่างน้อย

## 34 | ภาษาไทย

ที่สุด 12.7 มม. (1/2 ") และเป็นแบบเสริมความแข็งแรง

- ▶ อย่าเชื่อมต่อเครื่องเข้ากับระบบจ่ายน้ำประปาดื่มโดยไม่มีวาล์วป้องกันน้ำไหลกลับอย่างเด็ดขาด น้ำที่ผ่านวาล์วป้องกันน้ำไหลกลับถือว่าดื่มไม่ได้อีกต่อไป
- ▶ สายยางแรงดันสูงต้องไม่เสียหาย (อันตรายจากการระเบิด) ต้องเปลี่ยนสายยางแรงดันสูงที่เสียหายทันที ใช้เฉพาะสายยางและอุปกรณ์เชื่อมต่อที่แนะนำโดยบริษัทผู้ผลิตเท่านั้น
- ▶ สายยางแรงดันสูง พิดตึง และข้อต่อเพลลา มีความสำคัญต่อความปลอดภัยของเครื่อง ใช้เฉพาะสายยาง พิดตึง และข้อต่อเพลลา ที่แนะนำโดยบริษัทผู้ผลิตเท่านั้น
- ▶ นำเข้าเฉพาะน้ำที่กรองหรือน้ำสะอาดเท่านั้น

### การใช้งาน

- ▶ ก่อนใช้งาน ให้ตรวจสอบเครื่องและอุปกรณ์ทำงานว่าอยู่ในสภาพที่สมบูรณ์แบบและมีความปลอดภัยในการทำงานหรือไม่ อย่าใช้งานหากเครื่องไม่อยู่ในสภาพดีสมบูรณ์แบบ
- ▶ อย่าเล็งลำน้ำที่ฉีดออกมาตรงไปยังตัวท่าน หรือคนอื่น ๆ เพื่อทำความสะอาดเสื้อผ้า หรือรองเท้า
- ▶ อย่าสูบเข้าของเหลวที่มีตัวทำละลายกรดเข้มข้น อะซิโตน หรือตัวทำละลาย! ซึ่งรวมถึงน้ำมัน ทินเนอร์สี น้ำมันให้ความร้อน ไอน้ำที่พ่นออกมา

มีคุณสมบัติตัดไฟสูง ระเบิดได้ และเป็นพิษ

- ▶ เมื่อใช้เครื่องในพื้นที่อันตราย (เช่น สถานีเติมน้ำมัน) ต้องปฏิบัติตามกฎระเบียบเพื่อความปลอดภัยที่เกี่ยวข้อง ห้ามใช้เครื่องทำงานในสถานที่ที่อาจระเบิดได้
- ▶ ต้องวางเครื่องบนฐานที่มั่นคง
- ▶ หากใช้เครื่องในสถานที่คับแคบ ต้องตรวจสอบให้แน่ใจว่ามีการระบายอากาศที่เพียงพอ ตรวจสอบให้แน่ใจว่าได้ปิดสวิทช์ยานยนต์ทั้งหมดตลอดเวลาที่ทำความสะอาด
- ▶ เมื่อใช้เครื่องนี้ทำงาน ต้องใช้มือทั้งสองข้างตลอดเวลา ยื่อนำเครื่องขึ้นไปใช้บนบันได เมื่อใช้เครื่องบนระเบียงหรือบริเวณยกพื้นอื่น ๆ ท่านต้องมั่นใจว่าท่านสามารถมองเห็นขอบพื้นตลอดเวลา
- ▶ ใช้เฉพาะน้ำยาทำความสะอาดที่แนะนำโดยบริษัทผู้ผลิตเท่านั้น และปฏิบัติตามคำแนะนำการใช้งาน การกำจัด และค่าเตือนของบริษัทผู้ผลิต
- ▶ ส่วนประกอบที่นำไฟฟ้าทั้งหมดที่อยู่ในพื้นที่ทำงานต้องได้รับการป้องกันจากน้ำสะอาดกระเด็น
- ▶ โกวินฉัดต้องไม่ถูกหนีบอยู่ในตำแหน่ง "เปิด" ระหว่างทำงาน
- ▶ สวมชุดป้องกันที่เหมาะสมเพื่อป้องกันน้ำสกปรกที่มีคน เว้นแต่คนเหล่านั้นจะสวมใส่ชุดป้องกันด้วยเช่นกัน
- ▶ สวมใส่อุปกรณ์ป้องกันอันตรายส่วนบุคคล (PPE) ต.ย. เช่น แวนครอบตานิรภัย อุปกรณ์ป้องกันการหายใจ

เป็นต้น เพื่อป้องกันน้ำ อนุภาค และ/หรือละอองลอยที่ฉีดกลับมา จากชิ้นส่วน หากจำเป็น

- ▶ แรงดันสูงอาจทำให้มีวัตถุกระเด็น กลับ หากจำเป็น ให้สวมอุปกรณ์ ป้องกันตัวที่เหมาะสม เช่น แว่น ครอบตานิรภัย
- ▶ เพื่อหลีกเลี่ยงความเสียหายจาก ลำน้ำที่ฉีดออกมาด้วยแรงดันสูง ให้ ทำความสะอาดล้อ/วาล์วของ ยานยนต์จากระยะห่างอย่างน้อย 30 ซม. ปราบกฎการณเบืองต้นของ ความเสียหายคือล้อเปลี่ยนสี ล้อ/ วาล์วของยานยนต์ที่เสียหายอาจเป็น อันตรายอย่างยิ่ง
- ▶ ต้องไม่พ่นวัสดุที่มีแร่ใยหินและวัสดุ อื่นๆ ที่มีสารที่เป็นอันตรายต่อสุขภาพ ของท่านออกมา
- ▶ อย่าใช้น้ำยาทำความสะอาดโดยไม่ เจือจาง ผลิตภัณฑ์ที่ใช้จะมีความ ปลอดภัยเมื่อไม่มีกรดผสม ไม่มีด่าง หรือสารที่เป็นอันตรายต่อสภาพ แวดล้อม เราขอแนะนำให้เก็บน้ำยา ทำความสะอาดให้พ้นมือเด็ก ถ้า น้ำยาทำความสะอาดเข้าตา ให้ล้าง ด้วยน้ำปริมาณมากทันที และถ้า กลืนกินให้ปรึกษาแพทย์ทันที
- ▶ **อย่าใช้เครื่องฉีดน้ำแรงดันสูงโดย ไม่มีตัวกรอง หรือใช้ร่วมกับ ตัวกรองที่สกปรกหรือชำรุดอย่าง เด็ดขาด** การใช้เครื่องฉีดน้ำแรงดัน สูงโดยไม่มีตัวกรอง หรือใช้ร่วมกับ ตัวกรองที่สกปรกหรือชำรุด อาจ ทำให้การรับประกันเป็นโมฆะ

▶ ชิ้นส่วนโลหะอาจร้อนขึ้นหลังใช้งาน เป็นเวลานาน ให้สวมถุงมือป้องกัน หากจำเป็น

▶ หลีกเลี่ยงการชำระล้างด้วยแรงดัน สูงในสภาพอากาศที่เลวร้าย โดยเฉพาะอย่างยิ่งเมื่อมีความเสี่ยง ต่อการเกิดฟ้าผ่า

### การปฏิบัติงาน

- ▶ ผู้ใช้งานเครื่องต้องใช้เครื่องตามกฎ ระเบียบ เมื่อใช้เครื่องทำงาน ต้อง ตระหนักถึงสถานะเงื่อนไขที่กำหนด ในท้องถิ่น มีสติใส่ใจบุคคลอื่น โดยเฉพาะอย่างยิ่งเด็กๆ
- ▶ บุคคลที่สามารถใช้เครื่องนี้ได้ต้อง ได้รับการฝึกฝน หรือได้แสดง ให้เห็นว่ามีความสามารถใช้งาน เครื่องนี้ได้เท่านั้น ต้องไม่ให้เด็กหรือ เยาวชนใช้งานเครื่องนี้ (อันตราย จากอุบัติเหตุเนื่องจากการใช้งาน อย่างไม่ถูกวิธี)
- ▶ อย่าให้เด็ก บุคคลที่มีความบกพร่อง ทางกายภาพ ทางประสาทสัมผัส หรือ ทางจิต หรือขาดประสบการณ์ และ/หรือความรู้ และ/หรือบุคคลที่ไม่ คำนึงกับคำแนะนำเหล่านี้ นำ เครื่องมือทำสวนไปใช้งาน ข้อบังคับ ของประเทศอาจจำกัดอายุของ ผู้ใช้งานเครื่อง
- ▶ เด็กควรได้รับการดูแลเพื่อให้แน่ใจว่า พวกเขาจะไม่นำเครื่องมาเล่น
- ▶ อย่าทิ้งเครื่องโดยไม่มีกรควบคุม ดูแลในขณะที่เครื่องเปิดสวิทช์อยู่ อย่างเด็ดขาด

## 36 | ภาษาไทย

- ▶ **ลำน้ำที่ฉีดออกมาจากหัวฉีดแรงดันสูงทำให้เกิดการถอยกลับที่ปืนฉีด ท่านจึงควรถือปืนฉีดและก้านฉีดแบบพนละองด้วยมือทั้งสองข้างอย่างแน่นหนา**
- ▶ **อย่าใช้หัวฉีดน้ำแบบหมุนหรือหัวฉีดปลายแหลมทำความสะอาดยานยนต์**

**การขนย้าย**

- ▶ **ปิดสวิตช์มอเตอร์และทำเครื่องให้กระชับ ก่อนขนย้าย**

**การบำรุงรักษา**

- ▶ **ปิดสวิตช์เครื่องก่อนทำความสะอาดและบำรุงรักษาทุกครั้ง และก่อนเปลี่ยนส่วนประกอบ ดึงปลั๊กไฟ้า ออกจากเครื่องทำงานด้วยไฟฟ้า**
- ▶ **ส่งเครื่องให้ศูนย์บริการ บ็อช ที่ได้รับมอบหมายซ่อมแซมเท่านั้น**

**อุปกรณ์ประกอบและอะไหล่**

- ▶ **ใช้เฉพาะอุปกรณ์ประกอบและอะไหล่ที่ผ่านการรับรองจาก บ็อช เท่านั้น อุปกรณ์ประกอบและอะไหล่ของแท้**

**ข้อมูลทางเทคนิค**

เครื่องฉีดน้ำแรงดันสูง		AdvancedAquatak 150	AdvancedAquatak 160
หมายเลขสินค้า		3 600 HA7 7..	3 600 HA7 8..
กำลังไฟฟ้า	กิโวลต์	2.2	2.6
อุณหภูมิน้ำเข้า สูงสุด	°C	40	40
ประมาณน้ำเข้า น้อยสุด	ลิตร/วินาที	8	9.5
ความดันอนุญาตใช้งาน	MPa	15	16
แรงดันกำหนด	MPa	11	12

ค่าที่ใช้ได้กับแรงดันไฟฟ้าระบุ [U] 230 โวลท์ ค่าเหล่านี้อาจผิดเพี้ยนไปสำหรับแรงดันไฟฟ้าที่ต่ำกว่า และโมเดลที่สร้างสำหรับเฉพาะประเทศ

กระบวนการสตาร์ทเครื่องจะทำให้แรงดันไฟฟ้าหย่อนลงชั่วครู่ ในกรณีที่สภาพระบบสายไฟหลักไม่เอื้ออำนวย อาจเกิดคลื่นรบกวนอุปกรณ์/เครื่องอื่นๆ ได้ คาดว่าจะไม่เกิดการทำงานที่ผิดปกติเมื่อมีความต้านทานต่อไฟฟ้าสถิตย์ต่ำกว่า 0.276 โอห์ม หากมีข้อสงสัย กรุณาติดต่อการไฟฟ้าที่รับผิดชอบเรื่องการจ่ายกระแสไฟฟ้าของท่าน

**เท่านั้นที่รับประกันว่าเครื่องจะสามารถทำงานได้อย่างปลอดภัยและไม่ชำรุดเสียหาย**

**สัญลักษณ์**

สัญลักษณ์ต่อไปนี้มีความสำคัญต่อการอ่านและการทำความเข้าใจคู่มือการใช้งานเครื่อง กรุณาจดจำสัญลักษณ์และความหมายของสัญลักษณ์ การแปลความสัญลักษณ์ได้ถูกต้องจะช่วยให้ท่านใช้เครื่องได้ดีและปลอดภัยกว่า

สัญลักษณ์	ความหมาย
	ทิศทางการเคลื่อนที่
	ทิศทางการตอบสนอง
	น้ำหนัก
	เปิด
	ปิด
Lo	แรงดันต่ำ
Hi	แรงดันสูง
	อุปกรณ์ประกอบ

**ประโยชน์การใช้งานของเครื่อง**

ผลิตภัณฑ์ใช้สำหรับทำความสะอาดพื้นที่และวัตถุภายนอกบ้าน เครื่องมือ ยานยนต์ และเรือ โดยต้องใช้ใช้อุปกรณ์ที่เหมาะสมและน้ำยาทำความสะอาดที่ได้รับการรับรองจาก บ็อช

การใช้งานหมายถึงการทำงานที่มีอุณหภูมิโดยรอบระหว่าง 0 °C และ 40 °C

ผลิตภัณฑ์นี้ไม่เหมาะสำหรับการใช้งานเชิงพาณิชย์

เครื่องฉีดน้ำแรงดันสูง		AdvancedAquatak 150	AdvancedAquatak 160
อัตราน้ำที่ไหลผ่าน	ลิตร/วินาที	7.5	8.5
แรงดันด้านเข้าสูงสุด	MPa	1	1
ระบบหยุดทำงานอัตโนมัติ		●	●
น้ำหนักตามระเบียบการ-EPTA- Procedure 01:2014	กก.	21.1	23.4
ระดับความปลอดภัย		⊕ / I	⊕ / I
หมายเลขเครื่อง	ดูหมายเลขเครื่อง (แผ่นป้าย) บนเครื่องฉีดน้ำแรงดันสูง		
ค่าที่ใช้ได้กับแรงดันไฟฟ้าระบุ [U] 230 โวลต์ ค่าเหล่านี้อาจผิดเพี้ยนไปสำหรับแรงดันไฟฟ้าที่ต่ำกว่า และโมเดลที่สร้างสำหรับเฉพาะประเทศ			
กระบวนการสตาร์ทเครื่องจะทำให้แรงดันไฟฟ้าหย่อนลงเล็กน้อย ในกรณีที่สภาพระบบสายไฟหลักไม่เอื้ออำนวย อาจเกิดคลื่นรบกวนอุปกรณ์/เครื่องอื่นๆ ได้ คาดว่าจะไม่เกิดการทำงานที่ผิดปกติเมื่อมีความต้านทานต่อไฟฟ้าสถิตย์ต่ำกว่า 0.276 โอห์ม หากมีข้อสงสัย กรุณาติดต่อการไฟฟ้าที่รับผิดชอบเรื่องการจ่ายกระแสไฟฟ้าของท่าน			

## การประกอบและการปฏิบัติงาน

ขั้นตอน	ภาพประกอบ	หน้า
รายการสิ่งของที่จัดส่ง	1	59
การปรับค่ามจับ	2	60
การเชื่อมต่อสายยางส่งน้ำ		
แรงดันสูง/หัวฉีด	3	60
การเชื่อมต่อกับน้ำ	4	61
การเปิดและปิดสวิตช์	5-6	61
การทำความปลอดภัยตัวกรองน้ำ	7	62
การทำความปลอดภัยหัวฉีด	8	62
การเชื่อมต่อปืนฉีดแรงดันสูง กับก้านฉีด	9	62
การติดตั้งหัวฉีด	10	63
การเชื่อมต่อขวดน้ำยาทำ ความสะอาด	11	63
ก้านฉีดน้ำทรงพัดปรับได้		
การเชื่อมต่อปืนฉีดแรงดันสูง กับก้านฉีด		
การปรับลำน้ำที่ฉีดออกมา	12	64
ก้านฉีดน้ำแบบหมุน		
การเชื่อมต่อปืนฉีดแรงดันสูง กับก้านฉีด		
การปรับลำน้ำที่ฉีดออกมา	13	65
การเก็บปืนฉีด	14	66
การเก็บเข้าที่	15	66
การขนย้าย	16	67
การเลือกอุปกรณ์ประกอบ	17	68

## การเริ่มต้นปฏิบัติงาน

### เพื่อความปลอดภัยของท่าน



**คำเตือน!** ปิดสวิตช์และถอดปลั๊กไฟให้ออกก่อนปรับแต่งเครื่อง ทำความสะอาด หรือเมื่อสายเคเบิลหลุดตด เสียหาย หรือพันกันยุ่ง

ค่าแรงดันไฟฟ้าใช้งานคือ 230 V AC, 50 Hz (สำหรับประเทศนอกประชาคมยุโรป 220 V, 240 V แล้วแต่กรณี)

ให้ใช้เฉพาะสายไฟต่อพ่วงที่ผ่านการรับรอง สำหรับรายละเอียด กรุณาติดต่อศูนย์บริการ บ็อช ของท่าน

หากท่านต้องการใช้สายไฟต่อพ่วงเมื่อใช้เครื่องฉีดน้ำแรงดันสูงทำงาน ให้ใช้เฉพาะสายเคเบิลขนาดดังต่อไปนี้เท่านั้น:

– 2.5 มม.<sup>2</sup> – ความยาวสูงสุด 25 ม.

หมายเหตุ: หากใช้สายไฟต่อพ่วง สายไฟต่อพ่วงต้องมีสายดินและเชื่อมต่อกับปลั๊กไฟฟ้าไปยังสายเคเบิลดินของระบบไฟฟ้าของท่าน ดังที่อธิบายไว้ในกฎระเบียบเพื่อความปลอดภัย

หากมีข้อสงสัย ให้ปรึกษาช่างไฟฟ้าที่มีคุณสมบัติเหมาะสมหรือศูนย์บริการ บ็อช ที่ใกล้เคียงที่สุด



**คำเตือน:** สายไฟต่อพ่วงที่ไม่ตรงตามกฎระเบียบอาจเป็นอันตรายได้ สายไฟต่อพ่วงปลั๊กไฟฟ้า และเต้าเสียบจะต้องออกแบบให้กันน้ำได้ และผลิตไว้สำหรับใช้ภายนอกอาคาร

การเชื่อมต่อสายเคเบิลจะต้องแห้งและไม่วางบนพื้น เพื่อเพิ่มความปลอดภัยทางไฟฟ้า ให้ใช้อุปกรณ์ป้องกันไฟฟ้าดูด (RCD) ที่มีกระแสไฟฟ้าทริบไม่เกิน 30 mA ตรวจสอบอุปกรณ์ RCD ทุกครั้งเมื่อใช้งาน

หากสายไฟฟ้าชำรุด จะต้องเปลี่ยนใหม่โดยศูนย์บริการ บ็อช สำหรับผลิตภัณฑ์ที่ไม่ได้จำหน่ายในสหราชอาณาจักร  
**บริเตนใหญ่:**

**คำเตือน:** เพื่อความปลอดภัยของท่าน จำเป็นต้องเชื่อมต่อปลั๊กไฟฟ้าที่ติดมากับเครื่องเข้ากับสายไฟต่อพ่วง การเชื่อมต่อของสายไฟต่อพ่วงจะต้องได้รับการปกป้องจากน้ำที่สะอาด กระเด็น ซึ่งอาจทำจากยางหรือเคลือบด้วยยาง ต้องใช้สายไฟต่อพ่วงกับตัวม้วนแรงดึงสายเคเบิล

เพื่อป้องกันความเสียหายต่อเครื่อง อย่าปล่อยให้เครื่องทำงานโดยไม่มีน้ำ

## 38 | ภาษาไทย

**การปฏิบัติงาน****การสตาร์ท**

เชื่อมต่อสายยางส่งน้ำ (ไม่ได้จัดส่งมาด้วย) เข้ากับท่อน้ำประปาและเครื่อง

ตรวจสอบให้แน่ใจว่าสวิทช์ไฟฟ้าอยู่ในตำแหน่งปิด "0" และเชื่อมต่อเครื่องเข้ากับเต้าเสียบ

เปิดก๊อกน้ำ

กดลอคนิรภัย (ปุ่มหลังบนด้ามจับปืนฉีด) เพื่อปลดโก กดโกอย่างเต็มที่จนกว่าน้ำจะไหลคงที่เพื่อไล่อากาศออกจากเครื่องและสายยางส่งน้ำ ปลอยนิ้วออกจากโก กดลอคนิรภัย (ปุ่มหน้าบนด้ามจับปืนฉีด)

หมุนปุ่มบนสวิทช์ประธาน เล็งปืนฉีดลงด้านล่าง กดลอคนิรภัยเพื่อปลดโก กดโกอย่างเต็มที่

**ระบบหยุดทำงานอัตโนมัติ**

เครื่องนี้ถูกออกแบบให้มอเตอร์ปิดสวิทช์ในทันทีที่ท่อน้ำปล่อยนิ้วออกจากโกบนด้ามปืนฉีด

**ข้อแนะนำในการทำงาน****ทั่วไป**

ตรวจสอบให้แน่ใจว่าเครื่องฉีดน้ำแรงดันสูงวางอยู่บนพื้นราบ

อย่าจับสายยางแรงดันสูงไปข้างหน้ามากเกินไป หรืออย่าเลื่อนเครื่องฉีดน้ำแรงดันสูงโดยดึงสายยาง การกระทำดังกล่าวอาจทำให้เครื่องวางอย่างไม่มั่นคงและล้มได้

อย่าขดสายยางแรงดันสูงหรือเคลื่อนยานยนต์ที่บดสายยาง ปกป้องสายยางแรงดันสูงจากขอบหรือมุมที่แหลมคม

▶ อย่าใช้หัวฉีดน้ำแบบหมุนหรือหัวฉีดปลายแหลมทำความสะอาดยานยนต์

**คำเตือน!** "Patio Cleaner" ที่จัดส่งมาเหมาะสำหรับใช้งานบนพื้นผิวเรียบเท่านั้น! อย่าใช้สำหรับบันได อย่าล้มน้ำที่หัวฉีดที่หมุนขณะใช้เครื่องทำงาน!

**ข้อแนะนำในการทำงานสำหรับการทำความสะอาดด้วยน้ำยา**

▶ ใช้สารทำความสะอาดที่เหมาะสมที่ใช้เฉพาะสำหรับเครื่องฉีดน้ำแรงดันสูงเท่านั้น

เราขอแนะนำให้ท่านใช้น้ำยาทำความสะอาดเท่าที่จำเป็นเพื่อรักษาสภาพแวดล้อม ปฏิบัติตามสัดส่วนการเจือจางที่แนะนำบนฉลากสารทำความสะอาด

หัวฉีดโฟมแรงดันสูงที่จัดส่งมาพร้อมกับผลิตภัณฑ์นี้ มีตัวควบคุมเพื่อปรับปริมาณการใช้ยาทำความสะอาด สามารถปรับได้ตามความต้องการ

**วิธีทำความสะอาดที่แนะนำ**

**ขั้นตอนที่ 1:** ติดตั้งหัวฉีดน้ำทรงพัด และฉีดเอาสิ่งสกปรกหลายๆ ออก

**ขั้นตอนที่ 2:** ติดตั้งขวดโฟม และฉีดน้ำยาทำความสะอาดเท่าที่จำเป็น

**ขั้นตอนที่ 3:** ล้างสิ่งสกปรกที่หลุดออกมาและน้ำยาทำความสะอาดด้วยหัวฉีดน้ำทรงพัด

**หมายเหตุ:** เมื่อทำความสะอาดพื้นผิวในแนวตั้ง ให้ฉีดพ่นสิ่งสกปรก/น้ำยาทำความสะอาดจากด้านล่างและฉีดพ่นขึ้นด้านบน ชำระล้างออกจากด้านบนและฉีดพ่นลงด้านล่าง

**การใช้กับแหล่งน้ำทางเลือกอื่น**

เครื่องฉีดน้ำแรงดันสูงนี้เป็นแบบล่อน้ำด้วยตนเอง และสามารถดูดน้ำจากถังเก็บน้ำและแหล่งน้ำธรรมชาติได้ **สิ่งสำคัญ**คือต้องล้างตัวกรองน้ำ บิวซ์ ที่ทางเข้าของน้ำให้สะอาดและนำมาติดตั้งใช้งาน และน้ำที่ดูดเข้าต้องสะอาดเท่านั้น

**ถัง/ภาชนะแบบเปิดและแหล่งน้ำธรรมชาติ**

ให้ใช้ชุดอุปกรณ์ล่อน้ำด้วยตนเองซึ่งประกอบด้วย:

- ตะแกรงกรองดูดเข้าพร้อมวาล์วกักเก็บ
- สายยางส่งน้ำแบบเสริมความแข็งแรง 3 ม.
- ข้อต่อเพลาสากลต่อเข้ากับเครื่องฉีดน้ำแรงดันสูง

ชุดอุปกรณ์นี้ช่วยให้เครื่องฉีดน้ำแรงดันสูงสามารถดูดน้ำได้ถึง 0.5 ม. เหนือระดับน้ำในแหล่งน้ำในเวลาประมาณ 15 วินาที

จุ่มสายยาง 3 ม. ทั้งหมดลงในน้ำเพื่อไล่อากาศ เชื่อมต่อสายยางส่งน้ำ 3 ม. เข้ากับเครื่องฉีดน้ำแรงดันสูงโดยดูให้แน่ใจว่าตะแกรงกรองดูดเข้ายังคงจมอยู่ในแหล่งน้ำ

เปิดสวิทช์เครื่องฉีดน้ำแรงดันสูงโดยไม่เชื่อมต่อกับปืนฉีด ให้เดินเครื่องไปจนกว่าจะมีน้ำไหลออกจากสายยางแรงดันสูงอย่างสม่ำเสมอ หากไม่มีน้ำไหลออกภายใน 25 วินาที ให้ปิดสวิทช์เครื่องและตรวจสอบการเชื่อมต่อทั้งหมด เมื่อมีน้ำไหลออกมา ให้เปิดสวิทช์เครื่องฉีดน้ำแรงดันสูงและเชื่อมต่อกับปืนฉีด ก้านฉีด และหัวฉีด เพื่อทำงาน

สิ่งสำคัญคือต้องดูให้แน่ใจว่าสายยางและข้อต่อเพลาทันทีทั้งหมดอยู่ในสภาพที่ดี ผืนดินแน่นไม่ให้อากาศเข้า และประเก็นวงแหวนทั้งหมดไม่ชำรุดและวางเข้าที่อย่างถูกต้อง การเชื่อมต่อที่รั่วไหลอาจส่งผลต่อประสิทธิภาพการล่อน้ำด้วยตนเอง

**ถังเก็บน้ำที่มีก๊อกระบายน้ำ**

เมื่อเชื่อมต่อเครื่องฉีดน้ำแรงดันสูงเข้ากับถังเก็บน้ำที่มีก๊อกระบายน้ำที่เหมาะสม ให้เชื่อมต่อสายยางส่งน้ำ (ไม่ได้จัดส่งมา) เข้ากับก๊อกระบายน้ำก่อน เปิดก๊อกน้ำเพื่อให้น้ำเข้าไปแทนที่อากาศทั้งหมดในสายยาง จากนั้นจึงเชื่อมต่อเข้ากับเครื่องฉีดน้ำแรงดันสูง

## การแก้ไขปัญหา

ปัญหา	สาเหตุที่เป็นไปได้	มาตรการแก้ไข
มอเตอร์ไม่สตาร์ท	ไม่ได้เสียบปลั๊กไฟฟ้า	เสียบปลั๊กไฟฟ้า
	เต้าเสียบไฟฟ้าบกพร่อง	ใช้เต้าเสียบอื่น
	ฟิวส์ขาด	เปลี่ยนฟิวส์ใหม่
	สายไฟต่อพ่วงเสียหาย	ลองโดยไม่ใช้สายไฟต่อพ่วง
	อุปกรณ์ป้องกันมอเตอร์ถูกเรียกใช้งาน	ปล่อยให้เย็นลงประมาณ 15 นาที
	เย็นชื้น	รอให้ปัม/สายยางส่งน้ำ/อุปกรณ์ประกอบ ละลาย
มอเตอร์หยุดทำงาน	ฟิวส์ขาด	เปลี่ยนฟิวส์ใหม่
	แรงดันไฟฟ้าไม่ถูกต้อง	ตรวจสอบแรงดันไฟฟ้า แรงดันไฟฟ้าต้อง สอดคล้องกับข้อมูลจำเพาะบนแผ่นป้าย พิกัดรุ่น
	อุปกรณ์ป้องกันมอเตอร์ถูกเรียกใช้งาน	ปล่อยให้เย็นลงประมาณ 15 นาที
ฟิวส์ขาด	ขนาดของฟิวส์ไม่ถูกต้อง	เปลี่ยนที่วงจรไฟฟ้า ใลฟิวส์ที่มีขนาด สูงกว่าที่ตรงกับขนาดแอมป์ของ เครื่องฉีดน้ำแรงดันสูง
มอเตอร์สตาร์ทแต่ไม่มีแรงดัน	หัวฉีดบางส่วนอุดตัน	การทำความสะอาดหัวฉีด
มอเตอร์ "มีเสียง" แต่ไม่สตาร์ท	การจ่ายไฟฟ้าไม่เพียงพอ	ตรวจสอบว่าแรงดันของสายไฟฟ้าจาก แหล่งจ่ายกระแสไฟฟ้าตรงกับที่ระบุบน แผ่นป้ายพิกัดหรือไม่
	แรงดันไฟฟ้าต่ำเกินไปเนื่องจากใช้สายไฟ ต่อพ่วง	ตรวจสอบลักษณะเฉพาะของสายไฟ ต่อพ่วง
	ไม่ได้ใช้เครื่องเป็นเวลานาน	ติดต่อศูนย์บริการ บ็อกซ์ ของท่าน
	มีปัญหาที่ระบบหยุดทำงานอัตโนมัติ	ติดต่อศูนย์บริการ บ็อกซ์ ของท่าน
	อากาศในสายยางส่งน้ำ/ปัม	ปล่อยให้เครื่องฉีดน้ำแรงดันสูงวิ่งโดยเปิด ปืนฉีดและตั้งหัวฉีดที่แรงดันต่ำจนได้ แรงดันทำงานที่สม่ำเสมอ
แรงดันต่ำสม่ำเสมอแต่ต่ำเกินไป	การจ่ายน้ำไม่เพียงพอ	ตรวจสอบว่าการจ่ายน้ำสอดคล้องกับ ข้อมูลจำเพาะหรือไม่ สายยางส่งน้ำที่ เล็กที่สุดที่สามารถใช้ได้คือ 1/2" หรือ เส้นผ่าศูนย์กลาง 13 มม.
	ตัวกรองน้ำอุดตัน	ทำความสะอาดตัวกรองน้ำ
	สายยางส่งน้ำถูกบีบอัด	ทำสายยางส่งน้ำที่ขดงอให้ตรง
	สายยางแรงดันสูงยาวเกินไป	ถอดสายยางพ่วงต่อแรงดันสูงออก ลอง อีกครั้ง (สายยางพ่วงต่อสูงสุด 7 ม.)
	หัวฉีดเสื่อมสภาพ	เปลี่ยนหัวฉีดใหม่
	วาล์วสตาร์ท/หยุด เสื่อมสภาพ	เหนียวไถ 5 ครั้งติดต่อกันอย่างรวดเร็ว
หมายเหตุ: อุปกรณ์ประกอบบางตัวจะ ทำให้เกิดแรงดันต่ำ		
มอเตอร์ทำงานแต่มีแรงดันจำกัด หรือไม่มีแรงดันทำงาน	ไม่มีการจ่ายน้ำ	เชื่อมต่อการจ่ายน้ำ
	ตัวกรองน้ำอุดตัน	การทำความสะอาดตัวกรองน้ำ
เครื่องฉีดน้ำแรงดันสูงติดขึ้นเองอย่าง ผิดปกติ	หัวฉีดอุดตัน	ทำความสะอาดหัวฉีด
	ปัม/ปืนฉีดรั่ว	ติดต่อศูนย์บริการ บ็อกซ์ ของท่าน
นำรั่วจากเครื่อง	ปัมรั่ว	นำรั่วเล็กน้อยได้; ในกรณีที่มีรั่วมาก เกินไป ให้ติดต่อศูนย์บริการ

## 40 | ภาษาไทย

**การบำรุงรักษาและบริการ****การบำรุงรักษา****► หยุดเครื่อง ดึงปลั๊กไฟออกจากเต้าเสียบ และปลดการเชื่อมต่อ**

**หมายเหตุ:** เพื่อให้เครื่องมีอายุใช้งานยืนยาวและทำงานอย่างน่าเชื่อถือ ให้ทำการบำรุงรักษาต่อไปนี้อย่างสม่ำเสมอ ตรวจสอบเครื่องอย่างสม่ำเสมอเพื่อหาข้อบกพร่องที่เห็นได้ชัด เช่น จุดยึดติดที่หลวม และส่วนประกอบที่เสื่อมสภาพหรือเสียหาย

ตรวจสอบว่าฝาครอบและอุปกรณ์ป้องกันไม่เสียหายและติดตั้งอย่างถูกต้องแล้ว ทำการบำรุงรักษาหรือซ่อมแซมที่จำเป็นก่อนใช้งาน

เมื่อจำเป็นต้องเปลี่ยนสายไฟฟ้า ให้ส่งเครื่องให้บริษัท บ็อชหรือศูนย์บริการลูกค้าสำหรับเครื่องมือไฟฟ้า บ็อช ที่ได้รับมอบหมายทำการเปลี่ยนให้ เพื่อหลีกเลี่ยงอันตรายด้านความปลอดภัย

**หลังใช้งาน/เก็บเข้าที่**

ปิดสวิทช์ประธาน และกดไกเพื่อระบายน้ำออกจากสายยางแรงดันสูง

ทำความสะอาดส่วนภายนอกเครื่องอย่างถี่ถ้วนโดยใช้แปรงขนอ่อนหรือผ้า อย่านำตัวทำละลาย หรือสารขัดเงา เอาเศษสกปรกทั้งหมดออก โดยเฉพาะอย่างยิ่งตรงช่องระบายอากาศ

การเก็บเข้าที่เมื่อสิ้นสุดฤดูกาล: ระบายน้ำทั้งหมดออกจากปั๊มโดยปล่อยมอเตอร์วิ่งนานสองสามวินาที และเหนียวไกเพื่อปล่อยน้ำทั้งหมด

อย่าวางวัตถุอื่นไว้ที่ด้านบนของเครื่อง

เก็บไว้ในบริเวณที่ไม่เย็นจัดจนน้ำแข็งเกาะ

ตรวจสอบให้แน่ใจว่าสายเคเบิลไม่ถูกบีบอัดระหว่างการเก็บรักษา อย่าขาดของสายยางแรงดันสูง

**การบริการหลังการขายและคำแนะนำการใช้**

[www.bosch-do-it.com](http://www.bosch-do-it.com)

เมื่อต้องการสอบถามและสั่งซื้ออะไหล่ กรุณาแจ้งหมายเลขสินค้าหลักบนแผ่นป้ายรุ่นของเครื่องทุกครั้ง

ในกรณีประกัน ซ่อมแซม หรือซื้อชิ้นส่วนมาเปลี่ยน กรุณาติดต่อ ผู้ขายที่ได้รับแต่งตั้งเท่านั้น

**ไทย**

บริษัท โรเบิร์ต บ็อช จำกัด  
ชั้น 11 ตึกลิเบอร์ตี สแควร์  
287 ถนนสีลม บางรัก  
กรุงเทพฯ 10500  
โทรศัพท์ 02 6393111  
โทรสาร 02 2384783  
บริษัท โรเบิร์ต บ็อช จำกัด ตู้ ปณ. 2054  
กรุงเทพฯ 10501 ประเทศไทย  
[www.bosch.co.th](http://www.bosch.co.th)

ศูนย์บริการซ่อมและฝึกอบรม บ็อช  
อาคาร ลาซาลทาวเวอร์ ชั้น G ห้องเลขที่ 2  
บ้านเลขที่ 10/11 หมู่ 16  
ถนนศรีนครินทร์  
ตำบลบางแก้ว อำเภอบางพลี  
จังหวัดสมุทรปราการ 10540  
ประเทศไทย  
โทรศัพท์ 02 7587555  
โทรสาร 02 7587525

**การปกป้องสิ่งแวดล้อม**

อย่าเทสารเคมีที่ก่อมลพิษต่อสิ่งแวดล้อมลงในพื้นดิน น้ำบาดาลหรือบ่อ แม่น้ำลำธาร ฯลฯ

สำหรับการใช้สารทำความสะอาด ให้ปฏิบัติตามคำแนะนำบนบรรจุภัณฑ์และใช้ความเข้มข้นที่กำหนดอย่างถูกต้อง

สำหรับการทำความสะอาดยานยนต์ ให้ปฏิบัติตามระเบียบข้อบังคับของท้องถิ่น: อย่าปล่อยให้น้ำมันที่ปนออกมาไหลลงสู่บ่อบาดาล นำวัตถุติดกลับมาใช้ใหม่แทนการกำจัดของเสีย

**การกำจัดขยะ**

เครื่องฉีดน้ำแรงดันสูง อุปกรณ์ประกอบ และทิปท่อ ต้องนำไปแยกประเภทวัสดุเพื่อนำกลับมาใช้ใหม่โดยไม่ทำลายสภาพแวดล้อม

อย่าทิ้งเครื่องฉีดน้ำแรงดันสูงลงในถังขยะบ้าน!

**สำหรับประเทศสมาชิกประชาคมยุโรปเท่านั้น:**

 ตามกฎระเบียบยุโรป 2012/19/EU สำหรับของเสียประเภทเครื่องไฟฟ้าและอิเล็กทรอนิกส์ และตามกฎหมายของประเทศที่นำกฎระเบียบยุโรปมาใช้ ต้องแยกเก็บรวบรวมเครื่องไฟฟ้าและอิเล็กทรอนิกส์ที่ไม่สามารถใช้งานต่อไปได้ และนำไปกำจัดด้วยวิธีการที่เป็นมิตรต่อสภาพแวดล้อม

ขอสงวนสิทธิ์ในการเปลี่ยนแปลงโดยไม่ต้องแจ้งล่วงหน้า



## Bahasa Indonesia

### Petunjuk-Petunjuk untuk Keselamatan Kerja

#### Penjelasan simbol-simbol



Petunjuk umum adanya bahaya.



Janganlah sekali-kali mengarahkan semprotan air pada orang, hewan, alat atau komponen-komponen listrik. Perhatian: Semprotan bertekanan tinggi bisa membahayakan, jika disalah gunakan.



**Sesuai dengan peraturan-peraturan yang berlaku, alat tidak boleh disambungkan pada saluran air minum tanpa alat pemisah. Gunakanlah alat pemisah menurut peraturan IEC 61770 tipe BA.**

► **Air yang mengalir melalui alat pemisah bukan air minum lagi.**



**AdvancedAquatak 150** alat cocok untuk penggunaan pada pengadaan listrik dengan nilai sambungan  $\geq 100$  A per fasa dan tegangan nominal 230 V. Jika anda ragu-ragu, tanyakan pada pengada listrik.

### Petunjuk-petunjuk untuk keselamatan kerja untuk penyemprot tekanan tinggi



**Bacalah semua petunjuk-petunjuk untuk keselamatan kerja dan petunjuk-petunjuk untuk penggunaan.** Kesalahan dalam menjalankan petunjuk-petunjuk untuk

keselamatan kerja dan petunjuk-petunjuk untuk penggunaan dapat mengakibatkan kontak listrik, kebakaran dan/atau luka-luka yang berat.

**Label terkait keselamatan kerja dan label petunjuk pengoperasian yang ada pada alat memberikan petunjuk penting untuk pengoperasian yang aman.**

**Selain petunjuk-petunjuk dalam manual, semua peraturan tentang keselamatan kerja dan peraturan untuk menghindarkan terjadinya kecelakaan, harus ditaati.**

### Sambungan listrik

- Tegangan jaringan listrik harus sesuai dengan tegangan yang tercantum pada label tipe alat.
- Kami anjurkan supaya alat ini disambungkan pada stopkontak yang diamankan dengan sakelar pengaman terhadap arus penyimpangan FI (RCD) dengan kepekaan 30 mA.
- Cabut steker dari stopkontak, jika Anda tidak dapat mengawasi alat, juga untuk waktu yang singkat.
- Pengadaan listrik harus sesuai dengan peraturan IEC 60364-1.
- Jika kabel dari alat harus digantikan, orderkan produsen alat, satu Service Center yang resmi atau orang yang ahli dan berpengalaman untuk melakukannya, untuk menghindarkan terjadinya kecelakaan.

## 42 | Bahasa Indonesia

- ▶ Janganlah sekali-kali memegang steker jaringan dengan tangan yang basah.
- ▶ Janganlah mencabut steker selama Anda mengoperasikan alat.
- ▶ Janganlah melindas, menghimpit atau menarik kabel listrik atau kabel sambungan, karena kabel-kabel dapat menjadi rusak oleh karenanya. Lindungilah kabel terhadap suhu panas, minyak dan tepian yang tajam.
- ▶ Janganlah menggunakan alat jika kabel listrik atau komponen-komponen yang penting, seperti misalnya slang tekanan tinggi, pistol penyemprotan atau sarana-sarana pelindung rusak.
- ▶ Perhatian: kabel-kabel sambungan yang tidak memenuhi peraturan bisa membahayakan.
- ▶ Jika digunakan kabel sambungan, steker dan kopling harus kedap air. Kabel sambungan harus mempunyai penampang lintang yang disebutkan dalam petunjuk-petunjuk dalam manual dan terlindungi terhadap semprotan air. Sambungan tidak boleh berada dalam air.
- ▶ Jika steker pada kabel jaringan atau kabel sambungan digantikan, lindungan terhadap semprotan air dan stabilitas mekanik harus dipertahankan.
- ▶ Gunakanlah hanya slang yang dikuatkan dengan diameter 12,7 mm (1/2").
- ▶ Alat ini mutlak harus disambungkan dengan pentil arus balik pada saluran air minum. Air yang mengalir melalui pentil arus balik dianggap tidak dapat diminum.
- ▶ Slang tekanan tinggi tidak boleh dalam keadaan rusak (bahaya pecah). Slang tekanan tinggi yang rusak harus langsung digantikan. Hanya slang-slang dan sambungan-sambungan yang dianjurkan oleh produsen alat yang diizinkan untuk dipakai.
- ▶ Slang-slang tekanan tinggi, pesawat dalam dan kopling-kopling sangat penting untuk keselamatan kerja dengan alat. Gunakanlah hanya slang-slang, pesawat dalam dan kopling-kopling yang dianjurkan oleh produsen alat.
- ▶ Pada sambungan air masuk hanya boleh digunakan air yang bersih atau air yang disaring.

### Penggunaan

### Sambungan air

- ▶ Perhatikanlah peraturan-peraturan dari perusahaan pengada air Anda.
- ▶ Sambungan semua slang-slang harus kedap air.
- ▶ Alat dengan aksesorinya harus diperiksa apakah keberadaannya memenuhi peraturan dan dapat digunakan secara aman, sebelum pengoperasiannya. Jika keberadaannya tidak mulus, alat tidak boleh dioperasikan.
- ▶ Janganlah mengarahkan semprotan air pada diri sendiri atau orang lain untuk membersihkan pakaian atau sepatu.

- ▶ Cairan yang mengandung pelarut, zat asam yang tidak diencerkan, aseton atau cairan pelarut termasuk bensin, tiner dan minyak solar tidak boleh dihisap, karena kabut penyemprotannya sangat mudah terbakar, dapat meledak dan beracun.
- ▶ Jika alat digunakan di tempat yang berbahaya (misalnya pompa bensin), peraturan-peraturan terkait harus ditaati. Alat tidak boleh dioperasikan di ruangan yang terancam bahaya ledakan.
- ▶ Alat ini harus ditempatkan pada alas yang keras dan datar.
- ▶ Pada penggunaan di dalam ruang tertutup, perhatikanlah supaya ada pertukaran udara yang memadai. Perhatikanlah supaya kendaraan selama pembersihannya berada dalam keadaan mati (motor mati).
- ▶ Pengoperasian penyemprot tekanan tinggi harus dengan kedua belah tangan. Janganlah menggunakannya di atas tangga. Pada penggunaan di balkon atau tempat tinggi lainnya, perhatikanlah supaya Anda setiap saat melihat semua sisinya.
- ▶ Gunakanlah hanya deterjen yang dianjurkan oleh produsen alat dan taatilah petunjuk-petunjuk untuk penggunaan, pembuangan dan keselamatan kerja dari produsennya.
- ▶ Semua saluran listrik di bidang kerja harus dilindungi terhadap semprotan air.
- ▶ Tuas untuk mengoperasikan pistol penyemprotan selama penggunaan tidak boleh dijepit pada posisi „ON“.
- ▶ Pakailah pakaian pelindung yang tahan air semprotan. Janganlah mengoperasikan alat di dekat orang-orang lain, kecuali orang-orang ini memakai pakaian pelindung.
- ▶ Jika perlu, pakailah sarana pelindung (PPE/Personal Protective Equipment) yang cocok untuk semprotan air, misalnya kacamata pelindung, masker pelindung terhadap debu dsb., untuk melindungi terhadap air, partikel dan/atau aerosol yang dipantulkan dari benda-benda.
- ▶ Tekanan yang tinggi dapat membanting benda-benda. Jika perlu, pakailah sarana untuk melindungi diri, misalnya kacamata pelindung.
- ▶ Untuk menghindarkan terjadinya kerusakan oleh semprotan tekanan tinggi, ban kendaraan/pentil hanya boleh dibersihkan dengan jarak minimal 30 cm. Gejala dini untuk hal ini adalah perubahan warna dari ban. Ban kendaraan/pentil yang rusak sangat membahayakan.
- ▶ Bahan-bahan yang mengandung asbestos atau bahan-bahan lain yang mengandung zat yang berbahaya bagi kesehatan, tidak boleh disemprot.
- ▶ Janganlah menggunakan deterjen yang dianjurkan yang belum diencerkan. Produk-produk ini tidak membahayakan karena tidak mengandung zat asam, alkali atau zat yang berbahaya bagi lingkungan hidup. Kami anjurkan supaya deterjen disimpan di luar jangkauan

anak-anak. Jika mata terkena deterjen, mata harus segera dicuci dengan banyak air, jika deterjen tertelan, segera hubungi dokter.

► **Janganlah sekali-kali mengoperasikan penyemprot tekanan tinggi tanpa filter, dengan filter yang kotor atau yang rusak.**

Jika penyemprot tekanan tinggi digunakan tanpa atau dengan filter yang kotor atau rusak, garansi tidak berlaku lagi.

- Bagian-bagian dari logam dapat menjadi panas jika alat dioperasikan untuk waktu yang lama. Jika perlu, pakailah sarung tangan pelindung.
- Jika cuaca buruk, khususnya sebelum ada badai guntur, janganlah mengoperasikan penyemprot tekanan tinggi.

### Pengoperasian

- Orang yang mengoperasikan alat harus menggunakan alat sesuai dengan penjelasan dalam manual terkait penggunaannya. Keberadaan lokal harus diperhatikan. Selama bekerja dengan alat, penting sekali untuk memperhatikan orang lain, terutama anak-anak.
- Alat ini hanya boleh dioperasikan oleh orang-orang yang telah mendapat penjelasan tentang cara penggunaan dan pengendaliannya atau dapat membuktikan, bahwa ia dapat mengoperasikan alat. Alat ini tidak boleh digunakan oleh anak-anak atau orang muda.
- Janganlah sekali-kali mengizinkan anak-anak, orang-orang yang kurang

mampu secara fisik, sensoris atau mental atau kurang pengalaman dan/atau kurang mengetahui dan/atau orang-orang yang tidak mengenal petunjuk-petunjuk ini, menggunakan alat untuk pemeliharaan taman ini. Bisa jadi ada peraturan nasional yang menentukan batas usia pengguna alat ini.

- Awasilah anak-anak dan perhatikan supaya anak-anak tidak menggunakan alat untuk pemeliharaan taman ini sebagai mainan.
- Alat ini tidak boleh ditinggalkan tanpa pengawasan, jika alat hidup.
- Semprotan air yang keluar dari spuyer tekanan tinggi mengakibatkan bantingan. Oleh karena itu pistol penyemprotan dan spuyer bergagang panjang harus dipegang kencang dengan kedua belah tangan.
- Janganlah sekali-kali menggunakan spuyer rotasi atau pencil jet untuk membersihkan kendaraan-kendaraan.

### Transpor

- Sebelum mengangkut alat ini, alat harus dimatikan dan diamankan.

### Merawat

- Matikan alat sebelum Anda melakukan pekerjaan pembersihan dan perawatan dan sebelum mengganti aksesori. Cabutkan steker, jika alat disambungkan pada jaringan listrik.







- Reparasi hanya boleh dilakukan oleh bengkel Service Center Bosch yang resmi.

### Aksesori dan suku cadang

- Hanya aksesori dan suku cadang yang diizinkan oleh Bosch yang boleh digunakan. Aksesori asli dan suku cadang asli menjamin pengoperasian tanpa storing.

### Simbol-Simbol

Simbol-simbol berikut penting pada waktu membaca dan untuk mengerti petunjuk-petunjuk untuk penggunaan. Lihat dan ingati simbol-simbol dan artinya. Penafsiran yang betul dari simbol-simbol sangat membantu Anda untuk menggunakan perkakas listrik dengan jitu dan sesuai dengan petunjuk untuk keselamatan kerja.

Simbol	Arti
	Arah gerakan
	Arah reaksi
	Berat
	hidup
	mati
Lo	Tekanan rendah
Hi	Tekanan tinggi
	Aksesori

### Penggunaan alat

Alat ini cocok untuk membersihkan permukaan-permukaan dan obyek-obyek di luar gedung, untuk alat-alat, kendaraan-kendaraan dan kapal-kapal, jika dilengkapi dengan aksesoris yang memadai dan deterjen yang diizinkan oleh Bosch.

Penjelasan terkait penggunaan alat berlaku untuk suhu keliling antara 0 °C dan 40 °C.

Produk ini tidak cocok untuk penggunaan di dunia usaha dunia industri.

### Data teknis

Penyemprot tekanan tinggi		AdvancedAquatek 150	AdvancedAquatek 160
Nomor model		3 600 HA7 7..	3 600 HA7 8..
Masukan nominal	kW	2,2	2,6
Suhu air masuk maks.	°C	40	40
Banyaknya air masuk min.	l/min	8	9,5
Tekanan yang diizinkan	MPa	15	16
Tekanan nominal	MPa	11	12
Arus lintang	l/min	7,5	8,5
Banyaknya air masuk min.	MPa	1	1
Fungsi Autostop		●	●
Berat sesuai dengan EPTA-Procedure 01:2014	kg	21,1	23,4
Klasifikasi keamanan		⊕ / I	⊕ / I

Nomor serial lihat nomor model (label tipe) pada penyemprot tekanan tinggi  
Data-data berlaku untuk tegangan nominal [U] 230 V. Pada tegangan yang lebih rendah dan pada model khusus mancanegara data-data ini bisa berlainan.

Pada saat perkakas listrik dihidupkan, bisa terjadi penurunan tegangan dalam jaringan listrik untuk waktu yang pendek. Jika jaringan tidak memenuhi syarat, bisa terjadi gangguan terhadap alat-alat listrik lainnya. Jika impedansi jaringan di bawah 0,276 Ohm, tidak akan terjadi gangguan. Jika Anda ragu-rau, hubungilah pengada listrik Anda.

46 | Bahasa Indonesia

## Memasang dan menggunakan

Kegiatan	Gambar	Halaman
Pasokan standar	1	59
Menyetel pegangan	2	60
Menyambungkan slang tekanan tinggi/pistol penyemprotan	3	60
Sambungan air	4	61
Menghidupkan/mematikan	5-6	61
Membersihkan filter	7	62
Membersihkan spuyer	8	62
Menyambungkan spuyer bergagang panjang pada pistol penyemprotan	9	62
Memasang spuyer	10	63
Menyambungkan botol deterjen	11	63
Spuyer bergagang panjang dengan semprotan melebar yang variabel		
Menyambungkan spuyer bergagang panjang pada pistol penyemprotan		
Menyetel semprotan spuyer	12	64
Spuyer bergagang panjang dengan semprotan rotasi		
Menyambungkan spuyer bergagang panjang pada pistol penyemprotan		
Menyetel semprotan spuyer	13	65
Menyimpan pistol	14	66
Menyimpan	15	66
Transpor	16	67
Memilih aksesoris	17	68

## Cara menggunakan

### Demi keselamatan Anda



**Perhatian! Sebelum melakukan pekerjaan untuk merawat atau membersihkan, matikan alat ini dan cabutkan stekernya. Hal yang sama berlaku jika kabel listrik rusak, terpotong atau tersangkut.**

Tegangan jaringan 230 V AC, 50 Hz (untuk negara-negara bukan UE, 220 V, 240 V menurut adanya). Gunakanlah hanya kabel sambungan yang diizinkan. Informasi bisa diminta dari Service Center yang resmi.

Jika Anda hendak menggunakan penyemprot tekanan tinggi dengan kabel sambungan, penampang lintang berikut yang dibutuhkan:

– 2,5 mm<sup>2</sup> sampai kepanjangan maks. 25 m

Petunjuk: Jika digunakan kabel sambungan, kabel sambungan – seperti yang dijelaskan dalam peraturan keselamatan kerja – harus dilengkapi dengan penghantar kontak badan, yang disambungkan melalui steker dengan penghantar kontak badan dari instalasi listrik Anda.

Jika Anda ragu-ragu, mintakan penjelasan dari orang ahli listrik yang berpengalaman atau Service Center Bosch terdekat.



**HATI-HATI: Kabel sambungan yang tidak memenuhi peraturan bisa membahayakan. Kabel sambungan, steker dan kopling harus kedap air dan diizinkan untuk penggunaan di luar gedung.**

Sambungan kabel harus kering dan tidak boleh berada di tanah.

Untuk meningkatkan keselamatan, gunakanlah sakelar pengaman terhadap arus penyimpangan FI (RCD) dengan kepekaan maksimal 30 mA. Sakelar pengaman RCD ini harus diperiksa sebelum setiap penggunaan.

Jika kabel dari alat rusak, reparasinya hanya boleh dilakukan oleh Service Center Bosch yang resmi.

Petunjuk untuk produk yang **tidak dijual di GB:**

**PERHATIAN:** Demi keselamatan Anda, steker pada alat ini harus dikencangkan pada kabel sambungan. Kopling dari kabel sambungan harus dilindungi terhadap air semprotan, terdiri dari karet atau dilapisi dengan bahan karet. Kabel sambungan harus digunakan dengan pengikatan kabel terhadap tarikan.

Perhatikanlah bahwa alat ini tidak boleh dioperasikan tanpa air.

## Penggunaan

### Menghidupkan

Slang air (tidak termasuk pasokan) disambungkan pada pengadaan air dan alat.

Perhatikanlah supaya sakelar listrik berada pada posisi „0“ dan sambung alat pada stopkontak.

Buka keran air.

Gerakkan penguncian penghidupan (tombol di sebelah belakang pada gagang pistol), untuk membuka penguncian pelatuk. Tekan pelatuk sampai batas, hingga air mengalir rata dan tidak ada udara dalam alat dan slang tekanan tinggi. Pelatuk dilepaskan. Gerakkan penguncian penghidupan (tombol bagian depan pada gagang pistol).

Putarkan tombol jaringan. Arahkan pistol penyemprotan ke bawah. Gerakkan penguncian penghidupan, untuk membuka penguncian pelatuk. Tekan pelatuk sampai batas.

### Fungsi Autostop

Alat mematikan motor segera setelah pelatuk pada gagang pistol penyemprotan dilepaskan.

## Petunjuk-petunjuk untuk pemakaian

### Petunjuk umum

Perhatikanlah supaya penyemprot tekanan tinggi berada pada alas yang datar.

Janganlah menarik slang tekanan tinggi terlalu jauh ke depan atau jangan menarik penyemprot tekanan tinggi pada slangnya. Hal ini bisa mengakibatkan penyemprot tekanan tinggi tidak stabil dan terbalik.

Janganlah menekukkan slang tekanan tinggi dan jangan menindas dengan kendaraan di atasnya. Lindungi slang tekanan tinggi terhadap pinggiran atau tepian yang tajam.

- ▶ Janganlah sekali-kali menggunakan spuyer rotasi atau pencil jet untuk membersihkan kendaraan-kendaraan.

**Peringatan!** „Patio Cleaner“ hanya cocok untuk pengoperasian pada bidang datar! Janganlah menggunakannya untuk tangga. Janganlah sekali-kali menyentuh spuyer rotasi yang sedang beroperasi!

### Petunjuk-petunjuk untuk penggunaan untuk membersihkan dengan deterjen

- ▶ **Gunakanlah hanya deterjen yang pasti cocok untuk digunakan dengan penyemprot tekanan tinggi.**

Demi perlindungan lingkungan hidup, kami anjurkan supaya deterjen digunakan secara hemat. Taatilah petunjuk untuk mengencerkan deterjen yang tercantum pada labelnya.

Spuyer busa tekanan tinggi yang dipasok bersama dengan produk ini dilengkapi dengan pengatur untuk penyetelan banyaknya deterjen. Banyaknya deterjen disetelkan sesuai dengan kebutuhan.

### Cara membersihkan yang dianjurkan

**Langkah 1:** Pasangkan spuyer semprotan mendarat dan gunakan untuk menyingkirkan kotoran yang kasar.

**Langkah 2:** Pasangkan botol deterjen dan gunakan untuk membubuhkan sedikit deterjen.

**Langkah 3:** Bilaskan kotoran yang melarut dan deterjen dengan spuyer semprotan mendarat.

**Petunjuk:** Jika membersihkan permukaan yang tegak lurus, mulailah menyemproti kotoran/menyemprotkan deterjen dari bawah ke atas. Jika membilas, mulailah dari atas ke bawah.

### Sambungan pada pengadaan air alternatif

Penyemprot tekanan tinggi ini dilengkapi dengan penghisapan otomatis dan dapat menghisap air dari wadah

air atau sumber alami. **PENTING** sekali bahwa saringan (filter) dari Bosch pada sambungan air masuk dibersihkan dan dipasangkan dan air yang dihisap harus air yang bersih.

### Tangki/wadah terbuka dan sumber air alami

Gunakanlah set aksesoris penghisapan otomatis yang terdiri dari:

- saringan penghisapan dengan pentil arus balik
- slang penghisapan yang diperkuat sepanjang 3 m
- kopling serba guna ke penyemprot tekanan tinggi

Dengan aksesoris ini penyemprot tekanan tinggi dapat menghisap air 0,5 m di atas permukaan air. Hal ini bisa jadi lamanya kira-kira 15 detik.

Celupkan slang 3 m masuk ke dalam air sama sekali, untuk mendesak udara ke luar. Sambungkan slang penghisapan 3 m pada penyemprot tekanan tinggi dan perhatikan supaya saringan penghisapan tetap berada di dalam air.

Biarkan penyemprot tekanan tinggi jalan dengan pistol penyemprotan yang dilepaskan, sampai air mengalir ke luar dari slang tekanan tinggi secara rata. Jika setelah 25 detik masih belum ada air yang mengalir ke luar, matikan alat dan periksalah semua sambungan. Jika air mengalir, matikan penyemprot tekanan tinggi dan untuk penggunaannya, pasang pistol penyemprotan dan spuyer bergagang panjang.

Penting sekali bahwa slang dan kopling-kopling bermutu baik, disambungkan dengan ketat dan semua ring paking tidak rusak dan kedudukannya rata. Sambungan-sambungan yang bocor bisa menghalangi penghisapan.

### Wadah air dengan keran air ke luar

Jika penyemprot tekanan tinggi akan disambungkan pada tangki dengan keran air ke luar yang cocok, pertama satu slang air (tidak termasuk pasokan) harus disambungkan pada keran air. Buka keran, untuk mendesak ke luar semua udara yang berada di dalam slang, kemudian sambungkannya pada penyemprot tekanan tinggi.

## Mengatasi storing

Gejala	Sebab yang mungkin	Tindakan untuk mengatasi
Motor tidak menstart	Steker tidak disambungkan	Steker disambungkan
	Stopkontak rusak	Gunakan stopkontak lain
	Sekering putus	Gantikan sekering
	Kabel sambungan rusak	Coba tanpa kabel sambungan
	Perlindungan motor aktif	Motor didinginkan 15 men.
Motor berhenti	Beku	Pompa, slang air atau aksesori dibiarkan menjadi hangat
	Sekering putus	Gantikan sekering
	Tegangan jaringan tidak cocok	Periksa tegangan jaringan, harus sesuai dengan data pada label tipe alat
Sekering putus	Perlindungan motor aktif	Motor didinginkan 15 men.
	Sekering terlalu kecil ampere nominalnya	Sambungkan pada jaringan listrik dengan ampere yang cocok untuk penyemprot tekanan tinggi

## 48 | Bahasa Indonesia

Gejala	Sebab yang mungkin	Tindakan untuk mengatasi
Motor menstart, tetapi tidak ada tekanan	Spuyer agak tersumbat	Membersihkan spuyer
Ada bunyi motor tetapi tidak berfungsi	Tegangan jaringan tidak memadai	Periksalah apakah tegangan jaringan listrik sesuai dengan data pada label tipe alat.
	Tegangan terlalu rendah karena digunakan kabel sambungan	Periksalah apakah kabel sambungan cocok
	Alat tidak dipakai untuk waktu yang lama	Hubungi Service Center Bosch yang resmi
	Masalah dengan fungsi Autostop	Hubungi Service Center Bosch yang resmi
Tekanan berdenyut	Ada udara dalam slang air atau pompa	Penyemprot tekanan tinggi dijalankan dengan pistol penyemprotan terbuka, keran air terbuka dan spuyer pada tekanan rendah sampai tercapai tekanan kerja yang rata.
	Pengadaan air tidak cocok	Periksalah apakah sambungan air sesuai dengan data dalam bab data teknis. Slang air terkecil yang boleh dipakai adalah 1/2" atau Ø 13 mm
	Filter air tersumbat	Bersihkan filter air
	Slang air terhimpit atau tertekuk	Luruskan slang air
	Slang tekanan tinggi terlalu panjang	Lepaskan slang sambungan dari slang tekanan tinggi, panjang slang air maks. 7 m
	Tekanan rata tetapi terlalu rendah	Spuyer usang
Petunjuk: Aksesoris tertentu mengakibatkan tekanan yang rendah	Pentil start/stop usang	Pelatuk digerakkan 5 kali berturut-turut secara cepat
	Air tidak disambungkan	Sambungkan air
Motor menstart, tetapi tekanan terbatas atau tidak ada tekanan kerja	Filter tersumbat	Membersihkan filter
	Spuyer tersumbat	Bersihkan spuyer
	Pompa atau pistol penyemprotan bocor	Hubungi Service Center Bosch yang resmi
Penyemprot tekanan tinggi menstart sendiri	Pompa bocor	Kebocoran air sedikit tidak apa-apa; jika ada kebocoran yang besar, hubungi Service Center Bosch

## Rawatan dan servis

### Merawat

- **Sebelum melakukan pekerjaan pada alat, cabut steker dan putuskan sambungan air.**

**Petunjuk:** Lakukanlah pekerjaan rawatan berikut secara berkala, supaya alat tahan lama dan berfungsi dengan baik. Periksalah alat secara berkala, apakah terlihat ada kekurangan, seperti misalnya sambungan yang kendor atau bagian-bagian yang usang atau rusak.

Periksalah apakah sarana-sarana penutup dan pelindung mulus dan terpasang dengan betul. Jika perlu, sebelum menggunakan alat, lakukanlah pekerjaan rawatan atau reparasi.

Jika kabel listrik harus digantikan, pekerjaan ini harus dilakukan oleh Bosch atau Service Center untuk perkakas listrik Bosch yang resmi, supaya keselamatan kerja selalu terjamin.

### Setelah penggunaan/menyimpan

Matikan tombol untuk menghidupkan dan mematikan dan gerakkan pelatuk untuk mengosongkan slang tekanan tinggi.

Bagian luar dari penyemprot tekanan tinggi dibersihkan dengan sikat yang lunak dan lap. Air, tiner dan bahan untuk memolis tidak boleh digunakan. Singkirkan semua kotoran, terutama lubang ventilasi dari motor harus dibersihkan.

Menyimpan setelah musim penggunaan berakhir: Keluarkan semua air dari pompa dengan cara membiarkan motor jalan beberapa detik dan pelatuk digerakkan.

Janganlah meletakkan barang-barang lain di atas alat.

Simpanlah alat di tempat di mana suhu tidak menurun sampai di bawah titik beku.

Perhatikanlah supaya kabel selama alat disimpan tidak terjepit. Janganlah menekuk slang tekanan tinggi.



### Layanan pasca beli dan konseling terkait pengoperasian

[www.bosch-do-it.com](http://www.bosch-do-it.com)

Jika Anda hendak menanyakan sesuatu atau memesan suku cadang, sebutkan selalu nomor model yang terdiri dari 10 angka dan tercantum pada label tipe alat.

#### Indonesia

PT Robert Bosch  
Palma Tower 10<sup>th</sup> Floor  
Jl. RA Kartini II-S Kaveling 6 Sek II  
Pondok Pinang, Kebayoran Lama  
Jakarta Selatan 12310  
Indonesia  
Tel.: (021) 3005 5800  
Fax: (021) 3005 5801  
E-Mail: [boschpowertools@id.bosch.com](mailto:boschpowertools@id.bosch.com)  
[www.bosch-pt.co.id](http://www.bosch-pt.co.id)

### Melindungi lingkungan hidup

Bahan kimia yang berbahaya bagi lingkungan hidup tidak boleh mengalir ke dalam tanah, air tanah, kolam, sungai dan sebagainya.

Jika digunakan deterjen, taatilah petunjuk pada kemasan dan konsentrasi yang disebutkan dengan seksama.

Jika membersihkan kendaraan bermotor, taatilah peraturan-peraturan setempat: minyak yang tersemprot mutlak tidak boleh merembes ke dalam air tanah.

### Cara membuang

Penyemprot tekanan tinggi, aksesori dan kemasan sebaiknya didaur ulang sesuai dengan upaya untuk melindungi lingkungan hidup.

Janganlah membuang penyemprot tekanan tinggi dalam sampah rumah tangga!

#### Hanya untuk negara-negara UE:



Sesuai dengan peraturan Eropa 2012/19/EU terkait alat-alat elektro dan elektronika yang tidak dipakai lagi dan penerapannya dalam peraturan nasional mancanegara, alat-alat elektro dan elektronika yang rusak harus dikumpulkan secara terpisah dan didaur ulang sesuai dengan upaya untuk melindungi lingkungan hidup.

**Perubahan dapat terjadi tanpa pemberitahuan sebelumnya.**

## Tiếng Việt

### Các Nguyên Tắc An Toàn Giải thích các biểu tượng



Cảnh báo tổng quát các nguy hiểm vì sự an toàn.



Không bao giờ được hướng trực tiếp tia nước vào người, thú vật, các thiết bị hay bộ phận điện. Cảnh báo: Tia nước cao áp có thể gây nguy hiểm nếu bị sử dụng sai cách.



Dựa trên các qui định về việc ứng dụng, không bao giờ được sử dụng mạng nước uống được cho thiết bị ứng dụng mà không có hệ thống tách. Sử dụng hệ thống tách phù hợp với qui chuẩn IEC 61770 Type BA.

Nước chảy qua hệ thống tách được xem là nước không thể uống được.



Thiết bị **AdvancedAquatak 150** được thiết kế chỉ dành để sử dụng cho các công trình có công suất điện mỗi pha là  $\geq 100$  A, mạng lưới điện cung cấp có điện thế danh định là 230 V. Nếu như bạn không biết rõ, xin hãy liên hệ Cơ Quan Điện Lực nơi bạn ở.

## 50 | Tiếng Việt

**Chú Thích An Toàn cho máy phun rửa cao áp****Đọc kỹ mọi cảnh báo an toàn và mọi hướng dẫn.**

Không tuân thủ mọi cảnh báo và hướng dẫn được liệt kê dưới đây có thể bị điện giật, gây cháy và/hoặc bị thương tật nghiêm trọng.

**Sự cảnh báo và các ký hiệu thông tin đính kèm theo thiết bị cung cấp các thông tin quan trọng cho sự vận hành an toàn. Ngoài các thông tin trong hướng dẫn sử dụng, hãy tuân theo các qui định về an toàn chung và các qui định về phòng chống tai nạn.**

**Nguồn điện cung cấp**

- ▶ Điện thế ghi trong trong biển thông số phải phù hợp với điện thế nguồn.
- ▶ Chúng tôi khuyến nghị thiết bị này chỉ nối vào ổ cắm có bộ ngắt mạch bảo vệ. Bộ ngắt mạch này sẽ khởi hoạt khi phát sinh dòng điện dư 30 mA.
- ▶ Rút phích ra khỏi ổ cắm bất cứ khi nào máy để không, bất kể thời gian lâu mau.
- ▶ Các thiết bị cấp nối điện phải đáp ứng Qui chuẩn IEC 60364-1.
- ▶ Nếu dây cung cấp điện bị hư hỏng, dây phải do nhà cung cấp hoặc các đại lý dịch vụ hoặc do thợ chuyên môn thay để tránh nguy hiểm.

- ▶ Không bao giờ được chạm vào phích cắm nguồn bằng tay ướt.
- ▶ Không được rút phích cắm khi đang vận hành thiết bị.
- ▶ Không được cán qua, làm gấp hay kéo cáp cung cấp điện hay dây nối dài, nếu không, dây có thể bị hư hỏng. Bảo vệ cáp tránh nhiệt, dầu nhờn hay các cạnh bén.
- ▶ Không được sử dụng thiết bị ứng dụng nếu cáp cung cấp điện hay các bộ phận quan trọng khác vd. vòi chịu áp suất cao, cần bóp hay các thiết bị an toàn bị hư hại.
- ▶ Cảnh báo: Dây nối dài không thích hợp có thể trở nên nguy hiểm.
- ▶ Nếu sử dụng một dây nối dài, phích cắm và ổ cắm phải có cấu tạo chống thấm nước. Dây nối dài phải có mặt cắt ngang phù hợp với các hướng dẫn sử dụng và chống được nước bắn vào. Các đầu nối không được nằm trong nước.
- ▶ Khi thay các phích cắm trên cáp cung cấp điện hay dây nối dài, chặn bụi nước và sự ổn định cơ học phải được duy trì không thay đổi.

**Nối nước vào**

- ▶ Tuân theo các qui định của công ty cấp nước của bạn.
- ▶ Tất cả các vòi nối phải có các ron bịt kín khớp nối phù hợp.

- ▶ Bảo đảm vòi cung cấp nước có đường kính tối thiểu là 12,7 mm (1/2") và được gia lực.
- ▶ Không bao giờ được sử dụng thiết bị ứng dụng với nguồn nước uống được mà không có van chặn ngược dòng. Nước chảy ngược qua van chặn ngược dòng được xem là nước không thể uống được.
- ▶ Không để cho vòi chịu áp suất cao bị hư hại (nguy cơ toát ra). Vòi chịu áp suất cao bị hư hỏng phải được thay ngay. Chỉ sử dụng vòi và các chi tiết kết nối do nhà sản xuất khuyến nghị.
- ▶ Vòi chịu áp suất cao, các đầu nối vòi và khớp nối rất quan trọng cho sự an toàn của thiết bị ứng dụng. Chỉ sử dụng các vòi, đầu nối vòi và khớp nối do nhà sản xuất khuyến nghị.
- ▶ Chỉ nên sử dụng nước sạch hay đã được lọc để đưa vào máy.

### Ứng dụng

- ▶ Trước khi sử dụng, kiểm tra thiết bị và thiết bị thao tác có trạng thái hoàn hảo và an toàn để sử dụng. Không được sử dụng thiết bị nếu như thiết bị không trong tình trạng hoàn hảo.
- ▶ Không được hướng thẳng tia nước vào chính người bạn hay người khác để làm sạch quần áo hay giấy dép.
- ▶ Không bao giờ được đưa vào các loại dung môi lỏng, axít nguyên chất, aceton hay dung môi hòa tan! Điều này bao gồm xăng, dung môi pha sơn, dầu đốt lò sưởi. Các bụi sương này rất dễ cháy, nổ và độc hại.
- ▶ Các qui định phù hợp về an toàn phải được tuân theo khi sử dụng thiết bị ở những khu vực nguy hiểm (vd. trạm xăng dầu). Ở những nơi tiềm ẩn nguy cơ gây nổ cao là nơi cấm sử dụng thiết bị.
- ▶ Thiết bị phải được đặt trên một bề mặt vững chắc.
- ▶ Hãy lưu ý nếu như sử dụng máy trong một không gian hẹp, hãy bảo đảm rằng nơi này được thông thoáng. Nhớ chắc rằng tất cả các xe phải được tắt máy trong suốt thời gian phun rửa.
- ▶ Vận hành thiết bị này luôn luôn cần dùng đến cả hai tay. Không đứng trên thang khi sử dụng thiết bị. Bảo đảm khi sử dụng máy ở ban-công hay các nơi cao khác, bạn chắc chắn là luôn luôn nhìn thấy được các cạnh biên.
- ▶ Chỉ sử dụng chất tẩy rửa do nhà sản xuất kiến nghị và tuân theo cách ứng dụng, thải bỏ và các cảnh báo an toàn của nhà sản xuất chất tẩy rửa.
- ▶ Tất cả các bộ phận dẫn điện trong khu vực làm việc phải được bảo vệ, ngăn không cho nước bắn vào.
- ▶ Cò của cần bóp phải không bị kẹt khi ở vị trí "ON" trong khi hoạt động.
- ▶ Mặc quần áo bảo hộ thích hợp để bảo vệ từ các vật bị bắn tung

## 52 | Tiếng Việt

ra. Không được sử dụng thiết bị ứng dụng trong phạm vi có người, trừ khi họ cũng mặc quần áo bảo hộ.

- ▶ Nếu cần, hãy mang các trang thiết bị bảo hộ cá nhân (PPE) như kính bảo hộ an toàn, mặt nạ bảo vệ hô hấp v.v.. để ngăn nước, các mảnh nhỏ và/hay bụi nước từ các bộ phận phun ngược lại.
- ▶ Áp suất cao có thể làm cho các đồ vật bật nảy lên. Nếu cần, hãy trang bị thiết bị bảo hộ cá nhân như kính bảo hộ chẳng hạn.
- ▶ Có thể chỉ nên rửa sạch lốp xe/van lốp xe từ một khoảng cách tối thiểu là 30 cm, nếu không, tia nước cao áp có thể làm hư hại lốp xe/van lốp xe. Sự báo hiệu đầu tiên là sự bay màu của lốp xe. Làm hư hại lốp xe/van lốp xe có thể là sự cực kỳ nguy hiểm.
- ▶ Bạn không được phun rửa các loại vật liệu có hại cho sức khỏe như vật liệu chứa amiăng hoặc có chứa các chất độc hại khác.
- ▶ Không được sử dụng các chất tẩy rửa khi chưa được pha loãng. Các sản phẩm an toàn khi sử dụng là các chất không chứa axit, kiềm hay các chất gây hại cho môi trường. Chúng tôi đề nghị nên để các chất tẩy rửa ra ngoài tầm với của trẻ em. Nếu bị chất tẩy rửa văng vào mắt, rửa thật nhiều nước và nếu nuốt phải, phải đi khám bác sĩ ngay lập tức.

- ▶ **Không bao giờ được sử dụng máy phun rửa cao áp mà không có bộ lọc hay bộ lọc dơ hay đã bị hư.** Sử dụng máy phun rửa áp cao áp mà không có bộ lọc hay bộ lọc dơ hay đã bị hư có thể không có giá trị bảo hành.
- ▶ Các bộ phận kim loại có thể trở nên nóng sau thời gian dài sử dụng. Nếu cần, hãy mang găng bảo vệ tay.
- ▶ Tránh không rửa với áp suất cao trong tình trạng thời tiết xấu, đặc biệt là khi có nguy cơ có sấm sét.

### Vận hành

- ▶ Người vận hành phải sử dụng thiết bị đúng theo các quy định. Ông/bà phải xem xét đến các điều kiện của địa phương và lưu ý đến những người chung quanh, đặc biệt là trẻ em khi vận hành thiết bị.
- ▶ Thiết bị có thể chỉ được dành cho người đã biết cách sử dụng hay chứng tỏ được năng lực vận hành. Không được để cho trẻ con hay trẻ vị thành niên sử dụng thiết bị (nguy hiểm gây ra tai nạn do sử dụng thiết bị không đúng cách).
- ▶ Không bao giờ cho phép trẻ con, người thiếu năng, người có hạn chế về thể lực, khiếm khuyết giác quan hay không có kinh nghiệm/hoặc người không biết rõ các hướng dẫn này sử dụng dụng cụ làm vườn. Có thể

có các quy định của địa phương về tuổi của người sử dụng.

- ▶ Phải để ý đến trẻ con để bảo đảm chúng không nghịch máy.
- ▶ Không bao giờ được để thiết bị hoạt động để không mà không có sự giám sát.
- ▶ Tia nước từ miệng vòi cao áp tạo ra sự dội lại trên cần bóp. Vì thế bạn nên giữ cần bóp và cần phun thật chặt bằng cả hai tay.
- ▶ Không bao giờ được sử dụng vòi phun xoay hay tia phun để làm sạch xe có động cơ.

### Vận chuyển

- ▶ Tắt mô-tơ và ràng buộc chắc chắn thiết bị trước khi vận chuyển.

### Bảo trì







- ▶ Tắt thiết bị trước khi thực hiện mọi công việc như làm sạch, bảo trì và trước khi thay các bộ phận. Rút phích cắm nếu như thiết bị sử dụng điện nguồn.
- ▶ Sự sửa chữa có thể chỉ do các Trung Tâm Dịch Vụ Bosch thực hiện.

### Phụ kiện và phụ tùng thay thế

- ▶ Chỉ sử dụng phụ kiện và phụ tùng thay thế đã được hãng Bosch chấp nhận. Phụ kiện và phụ tùng thay thế chính hãng bảo đảm cho thiết bị có thể hoạt động an toàn và không gặp bất cứ hỏng hóc nào.

### Các Biểu Tượng

Các biểu tượng sau đây mang ý nghĩa quan trọng để suy diễn và hiểu các hướng dẫn sử dụng. Xin vui lòng lưu ý đến các biểu tượng và ý nghĩa của chúng. Sự hiểu đúng các biểu tượng sẽ giúp bạn sử dụng máy một cách tốt và an toàn hơn.

Biểu Tượng	Ý Nghĩa
	Chiều chuyển động
	Chiều phản ứng
	Trọng lượng
	Mở
	Tắt
Lo	Áp suất thấp
Hi	Áp suất cao
	Phụ kiện

### Dành sử dụng cho

Sản phẩm được thiết kế dùng để làm sạch các khu vực hay đồ vật bên ngoài nhà như dụng cụ, xe hay ghe thuyền nếu như sử dụng đúng các phụ kiện thích hợp cũng như các chất tẩy rửa được hãng Bosch chấp nhận.

Mục đích sử dụng liên quan đến hoạt động với nhiệt độ chung quanh trong phạm vi 0 °C và 40 °C.

Sản phẩm này không dành sử dụng cho chuyên dụng.

54 | Tiếng Việt

## Thông số kỹ thuật

Máy phun rửa cao áp		AdvancedAquatak 150	AdvancedAquatak 160
Mã số máy		3 600 HA7 7..	3 600 HA7 8..
Công suất danh định	kW	2,2	2,6
Nhiệt độ cung cấp tối đa	°C	40	40
Năng suất cung cấp tối thiểu	l/min	8	9,5
Áp suất cho phép	MPa	15	16
Áp suất làm việc	MPa	11	12
Tốc độ dòng chảy	l/min	7,5	8,5
Áp suất vào tối đa	MPa	1	1
Chức năng ngừng tự động		●	●
Trọng lượng theo Quy trình EPTA-Procedure 01:2014 (chuẩn EPTA 01:2014)	kg	21,1	23,4
Cấp độ bảo vệ		⊕ / I	⊕ / I
Mã seri sản xuất		Xem mã seri sản xuất (biển thông số) trên máy phun rửa cao áp.	

Các giá trị đã cho có hiệu lực cho điện thế danh định [U] 230 V. Đối với điện thế thấp hơn và các loại máy dành riêng cho một số quốc gia, các giá trị này có thể thay đổi.

Chu trình khởi động làm giảm điện áp xảy ra thoáng nhanh. Sự gây nhiễu động đối với các thiết bị/máy móc khác có thể xảy ra trong trường hợp ở vào tình trạng không thuận lợi của hệ thống điện nguồn. Không có sự cố xảy ra đối với hệ thống có trở kháng dưới 0,276 ohm. Nếu như không biết rõ, xin vui lòng liên hệ Cơ Quan Điện Lực nơi bạn ở.

## Lắp và Vận Hành

Loại công việc	Hình ảnh	Trang
Các món được giao	1	59
Điều chỉnh Tay nắm	2	60
Nối vòi nguồn nước cung cấp áp suất cao/miệng vòi	3	60
Nối nước vào	4	61
Mở và Tắt	5-6	61
Làm sạch bộ lọc nước	7	62
Làm sạch miệng vòi	8	62
Lắp cần bóp áp suất cao vào ống phun	9	62
Miệng Vòi Nối Ghép	10	63
Lắp chai chứa chất tẩy rửa	11	63
Ống phun Quạt chuyển đổi được		
Lắp cần bóp áp suất cao vào ống phun		
Điều chỉnh tia nước	12	64
Ống phun xoay		
Lắp cần bóp áp suất cao vào ống phun		
Điều chỉnh tia nước	13	65
Nơi đặt cần bóp	14	66
Sắp đặt	15	66
Vận chuyển	16	67
Chọn phụ tùng	17	68

## Bắt đầu

### Cho Sự An Toàn của Bạn



**Cảnh báo! Tắt máy, rút phích cắm ra khỏi nguồn điện trước khi điều chỉnh, làm sạch hay nếu cáp điện bị đứt, hư hại hay bị vướng.**

Điện thế hoạt động là 230 V AC, 50 Hz (các quốc gia ngoài EU có điện thế ứng dụng là 220 V, 240 V). Chỉ sử dụng cáp nối dài được chấp thuận. Liên hệ với Trung Tâm Dịch Vụ Bosch của bạn để biết thêm chi tiết.

Nếu bạn muốn sử dụng cáp nối dài khi vận hành máy phun rửa cao áp của bạn, chỉ có cáp có kích thước sau đây mới được sử dụng:

– 2,5 mm<sup>2</sup> – chiều dài tối đa 25 m

Ghi chú: Nếu sử dụng cáp nối dài, cáp phải có dây tiếp đất và nối thông qua phích cắm vào cáp tiếp đất của hệ thống cung cấp điện của bạn, phù hợp với các qui định an toàn đã được chỉ định rõ.

Nếu chưa hiểu rõ, hãy liên hệ một thợ điện chuyên nghiệp hay Trung Tâm Dịch Vụ Bosch gần nhất.



**CẢNH BÁO! Cáp nối dài không phù hợp có thể nguy hiểm. Cáp nối dài, phích cắm, phích và ổ cắm phải có cấu tạo chống nước và có mục đích sử dụng ngoài trời.**

Cáp nối phải được giữ khô ráo và để cách mặt đất.

Sử dụng thiết bị ngắt mạch tự động (RCD) với cường độ dòng điện ngắt mạch không lớn hơn 30 mA để nâng cao sự an toàn về điện. Luôn luôn kiểm tra RCD của bạn trước mỗi lần sử dụng.

Nếu như dây được cung cấp bị hư hỏng, dây phải do Trung Tâm Dịch Vụ Bosch thay.

đối với các sản phẩm **không bán ở Anh:**

**CẢNH BÁO:** Vì sự an toàn của bạn, điều yêu cầu là phích cắm vào máy phải được nối với dây nối dài. Bộ cắm nối của dây nối dài phải ngăn được nước bắn vào, được làm bằng cao su hay phủ lớp cao su. Dây nối dài phải được sử dụng cùng với bộ phận chống căng cáp.

Để ngăn ngừa thiết bị bị hư hỏng, không cho máy hoạt động mà không có nước.

## Vận Hành

### Bắt đầu

Gắn vòi cung cấp nước (không giao kèm) vào nguồn cung cấp nước và vào máy.

Nối thiết bị ứng dụng vào nguồn điện chính và nhớ chính đặt công tắc chính nằm ở vị trí tắt.

Mở vòi nước.

Nhấn khóa an toàn (nút phía sau cần bóp) để nhả cò. Nhấn hết cò vào cho đến khi nước chảy ra đều để tổng không khí ra khỏi máy và vòi cung cấp nước. Nhả cò ra. Nhấn khóa an toàn (nút phía trước cần bóp).

Mở nút công tắc chính. Hướng cần bóp xuống dưới. Nhấn cò khóa an toàn để nhả cò. Nhấn cò hoàn toàn vào.

### Chức năng ngừng tự động

Máy được thiết kế để tắt mô-tơ khi cò bấm trên cần bóp được nhả ra.

## Hướng Dẫn Sử Dụng

### Tổng quát

Bảo đảm máy phun rửa cao áp nằm trên mặt phẳng. Không được cố với tới bằng vòi áp suất cao hay di chuyển máy phun rửa cao áp bằng cách kéo vòi ống, điều này có thể làm cho máy bị mất thăng bằng và lật xuống.

Không được làm xoắn hay thắt nút hoặc để xe có động cơ cán qua vòi áp suất cao. Không được để trần vòi áp suất cao vào cạnh hay góc bèn.

- ▶ Không bao giờ được sử dụng vòi phun xoay hay tia phun để làm sạch xe có động cơ.

**CẢNH BÁO!** Thiết Bị Lau Chùi Hành Lang được cung cấp được thiết kế chỉ để dùng cho các bề mặt phẳng ! Đừng cố tình sử dụng cho các bề mặt không liên lạc. Không cố tình chạm vào mũi phun xoay khi vận hành máy !

### Lời khuyên cho việc làm sạch bằng chất tẩy rửa

#### ▶ Chỉ sử dụng chất dùng làm sạch đặc biệt thích hợp cho máy phun rửa cao áp.

Chúng tôi khuyến nghị bạn nên sử dụng chất tẩy rửa một cách vừa phải vì môi trường. Tuân theo khuyến cáo pha loãng trên nhãn chất tẩy rửa.

Miếng vòi phun bọt áp suất cao được cấp kèm theo sản phẩm này bao gồm cả bộ phận điều tiết kiểm soát chất tẩy rửa. Xin điều chỉnh theo nhu cầu.

### Giới thiệu phương pháp làm sạch

**Bước 1:** Gắn mũi cố định phun tia quạt và tẩy rửa bụi đất đóng thành mảng.

**Bước 2:** Gắn bình bọt và phun chất tẩy rửa sơ qua.

**Bước 3:** Xối rửa các bụi đất đã rã và phun chất tẩy rửa bằng mũi phun tia quạt.

**Ghi Chú:** Khi phun tổng chất bẩn/chất tẩy rửa để làm sạch bề mặt đứng, phun từ chân đáy và hướng lần lên trên. Rửa từ phía trên và đi lần xuống dưới.

### Sử dụng các nguồn nước thay thế khác

Máy phun rửa cao áp này có chức năng tự môi và có thể hút nước từ bồn chứa và các nguồn nước tự nhiên. Điều **QUAN TRỌNG** là nước phải sạch và bộ phận lọc đầu vào của Bosch phải sạch và lắp vừa với máy.

### Mở bồn chứa/vật chứa và nguồn nước tự nhiên

Sử dụng bộ phụ kiện Tự Môi bao gồm:

- Bộ lọc đầu vào có van một chiều
- Ống cấp nước gia lực 3 m
- Khớp nối phổ thông vào máy phun rửa cao áp

Cách này làm cho máy phun rửa cao áp hút được nước lên tới 0,5 m trên mực nước nguồn trong khoảng 15 giây.

Đim 3 m ống xuống nước để tổng không khí ra. Nối ống cấp nước 3 m vào máy phun rửa cao áp. Bảo đảm bộ lọc đầu vào vẫn đang nằm chìm dưới nguồn nước.

Cho máy phun rửa cao áp hoạt động nhưng không gắn ống phun vào cho đến khi dòng nước từ vòi cao áp đã hoạt động ổn định. Ngừng ngay nếu như nước không hoạt động ổn định trong vòng 25 giây. Kiểm

**56 | Tiếng Việt**

tra lại các mối lắp nối. Tắt máy và lắp cân bóp, ống phun và mũi phun vào để hoạt động.

Điều quan trọng phải bảo đảm là tất cả ống, khớp lắp nối phải có chất lượng tốt, giữ kín khí và tất cả các bộ đệm còn tốt tốt và nằm đúng vị trí. Không thực hiện đúng như trên có thể ảnh hưởng đến hiệu quả của sự tự mỗi nước.

**Bồn Chứa Nước có lắp vòi cấp nước**

Khi lắp nối máy phun rửa cao áp vào bồn nước có vòi cấp nước thích hợp, trước hết nối ống cấp nước (không cấp kèm) vào vòi cấp nước của bồn chứa. Mở vòi để nước tổng không khí trong ống ra và sau đó nối vào máy phun rửa cao áp.

**Xử lý Hỏng hóc**

Có vấn đề	Nguyên Nhân Có Thể Gây Ra	Biện Pháp Sửa Chữa
Mô-tơ không khởi hoạt	Chưa cắm phích	Cắm phích vào
	Ổ cắm của nguồn điện chính bị hỏng	Sử dụng ổ cắm khác
	Cầu chì hư/nổ	Thay cầu chì
	Cáp nối dài bị hư hỏng	Thử không sử dụng cáp nối dài
	Bộ bảo vệ mô-tơ được kích hoạt	Để cho nguội xuống 15 phút
	Đóng băng	Đợi cho bơm/vòi cung cấp nước/phụ kiện tan băng
Mô-tơ ngừng	Cầu chì hư/nổ	Thay cầu chì
	Điện thế nguồn không đúng	Kiểm tra điện thế nguồn có phù hợp với đặc tính kỹ thuật trên biển loại máy
	Bộ bảo vệ mô-tơ được kích hoạt	Để cho nguội xuống 15 phút
Cầu chì nổ	Cầu chì không đúng cường độ dòng điện định mức	Đổi sang nguồn điện cao hơn mức amp tiêu thụ của máy phun rửa cao áp
Mô-tơ hoạt động nhưng không có áp suất	Miệng vòi bị nghẽn một phần	Làm sạch miệng vòi
Mô-tơ "phát ra tiếng" nhưng không khởi động	Nguồn điện cung cấp không đủ	Kiểm tra điện thế của nguồn điện cung cấp có phù hợp với điện thế trên biển thông số
	Điện thế giảm do sử dụng cáp nối dài	Kiểm tra đặc tính kỹ thuật của cáp nối dài
	Thiết bị ứng dụng từ lâu không được sử dụng	Liên hệ Trung Tâm Dịch Vụ Bosch
	Trục trặc với thiết bị TSS (Hệ Thống Ngừng Toàn Bộ)	Liên hệ Trung Tâm Dịch Vụ Bosch
Áp suất dao động	Có hơi trong vòi cung cấp nước vào/bơm	Để cho máy phun rửa cao áp hoạt động mà cân bóp và miệng vòi để mở ở áp suất thấp cho đến khi có lại áp suất làm việc thông thường
	Nước cung cấp không đủ	Kiểm tra nguồn cung cấp nước có phù hợp với các đặc điểm kỹ thuật. Đặc điểm kỹ thuật tối thiểu của đường kính vòi cung cấp nước là 1/2" hay 13 mm
	Bộ lọc nước bị nghẽn	Làm sạch bộ lọc nước
	Vòi cung cấp nước bị bóp nghẹt	Duỗi thẳng vòi cung cấp nước bị xoắn hay thắt nút
	Vòi áp suất cao quá dài	Tháo vòi áp suất cao nối dài ra. Thử lại (chiều dài vòi nối dài tối đa 7 m)



Có vấn đề	Nguyên Nhân Có Thể Gây Ra	Biện Pháp Sửa Chữa
Áp suất quá thấp, nhưng ổn định	Miếng vòi mòn Van khởi động/ngừng mòn	Thay miếng vòi Kích hoạt nhanh cò (cần bóp) năm lần liên tiếp
Ghi chú: Một số loại phụ kiện thông thường tạo ra áp suất thấp		
Mô-tơ khởi động nhưng có áp suất hạn chế hay không có áp suất làm việc	Không có nước cung cấp Bộ lọc nước bị nghẽn Miếng vòi bị nghẽn	Nối nước cung cấp vào Làm sạch bộ lọc nước Làm sạch miếng vòi
Máy phun rửa cao áp tự khởi động không bình thường	Bơm/cần bóp bị rò rỉ	Liên hệ Trung Tâm Dịch Vụ Bosch
Nước rò rỉ từ máy	Bơm bị rò rỉ	Sự rò rỉ nước chút ít có thể chấp nhận được; trong trường hợp rò rỉ quá nhiều, liên hệ Trung tâm Dịch vụ

## Bảo Dưỡng và Bảo Quản

### Bảo Dưỡng

- ▶ **Tắt máy, rút phích ra khỏi nguồn cung cấp điện và tháo nguồn cung cấp nước.**

**Ghi Chú:** Để bảo đảm sự hoạt động lâu dài và đáng tin cậy, thực hiện thường xuyên việc bảo trì sau đây.

Thường xuyên kiểm tra các khuyết điểm để nhận thấy như những điểm lắp nối không chặt, bị mòn hay các bộ phận bị hư hỏng.

Kiểm tra các nắp che và chắn không bị hư hỏng và được lắp đúng cách. Thực hiện việc bảo trì cần thiết hay sửa chữa trước khi sử dụng.

Nếu như cần phải thay dây dẫn điện thì công việc này phải do hãng Bosch, hay một đại lý được Bosch ủy nhiệm thực hiện để tránh gặp sự nguy hiểm do mất an toàn.

### Sau khi sử dụng/Bảo quản

Tắt công tắc chính và kích hoạt cò để tháo nước ra khỏi vòi áp suất cao.

Lau sạch toàn bộ mặt ngoài của máy bằng vải hay cọ mềm. Không được sử dụng nước, dung môi hay chất đánh bóng. Tẩy sạch cặn bám, đặc biệt là ở các khe thông gió.

Cuối mùa bảo quản: Tháo nước ra khỏi bơm và cho mô-tơ hoạt động trong vài giây. Kéo cò để tháo toàn bộ nước ra.

Không được đặt các vật dụng khác lên trên máy.

Bảo quản ở khu vực không bị băng giá.

Bảo đảm cáp không bị rối khi bảo quản. Không được làm xoắn, thắt nút vòi áp suất cao.

## Dịch Vụ Sau Khi Bán và Dịch Vụ Ứng Dụng

[www.bosch-do-it.com](http://www.bosch-do-it.com)

Trong mọi thư từ giao dịch và đơn đặt hàng phụ tùng thay thế, xin vui lòng luôn luôn viết đủ 10 con số mã hàng hóa ghi trên nhãn loại máy của máy.

### Việt Nam

Công ty Trách Nhiệm Hữu Hạn Robert Bosch

Việt Nam, PT/SVN

Tầng 10, 194 Golden Building

473 Điện Biên Phủ

Phường 25, Quận Bình Thạnh

Thành Phố Hồ Chí Minh

Việt Nam

Tel.: (08) 6258 3690 Ext 413

Fax: (08) 6258 3692

hie.u.lagia@vn.bosch.com

[www.bosch-pt.com](http://www.bosch-pt.com)

## Bảo Vệ Môi Trường

Các hóa chất nguy hiểm cho môi trường không được để cho chảy thấm vào đất, nước ngầm hay ao hồ, sông suối v.v..

Đối với việc sử dụng các chất làm sạch, tuân theo các hướng dẫn trên bao bì và nồng độ chính xác được định rõ.

Đối với việc rửa xe có động cơ, phải tuân theo các qui định của địa phương: Không để cho dầu được phun ra thấm vào nguồn nước ngầm. Tái chế các nguyên liệu thô thay vì thải bỏ.

## 58 | Tiếng Việt

### Thải bỏ

Máy phun rửa cao áp, phụ kiện, và bao bì phải được phân loại để tái chế theo hướng thân thiện với môi trường.

Không được thải bỏ máy phun rửa cao áp vào rác sinh hoạt gia đình!

#### Chỉ dành cho các nước EC:



Căn cứ theo những quy tắc hướng dẫn thực hiện 2012/19/EU của khối EC đối với các Thiết Bị Điện và Điện Tử được Thải Bỏ và sự thực thi thành luật quốc gia, các thiết bị điện và điện tử không còn sử dụng được nữa phải thu hồi riêng biệt và thải bỏ theo cách ứng xử đúng với môi trường.

Được quyền thay đổi nội dung mà không phải thông báo trước.

1



21,1 kg

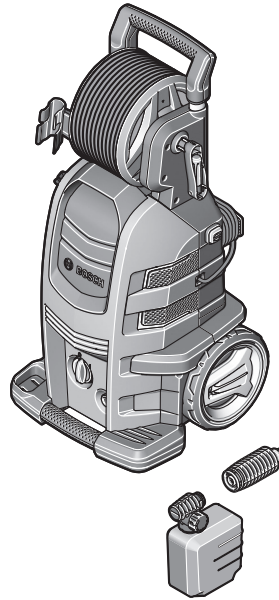
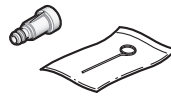
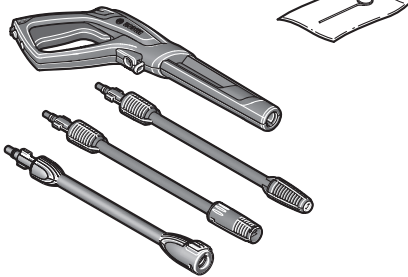
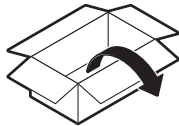

**AdvancedAquatak 150**



23,4 kg

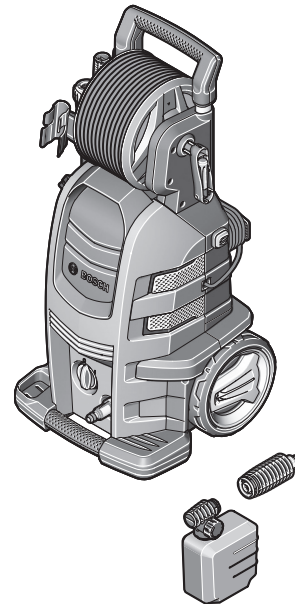
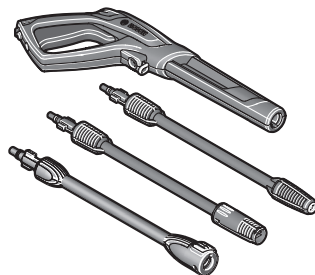
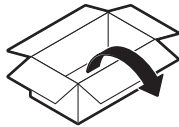

**AdvancedAquatak 160**



2

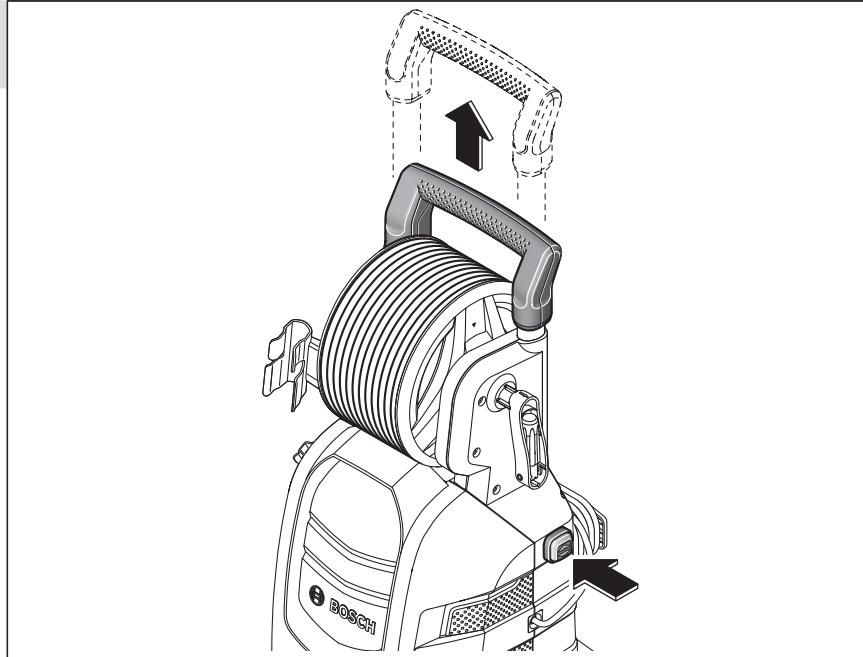

3

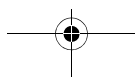
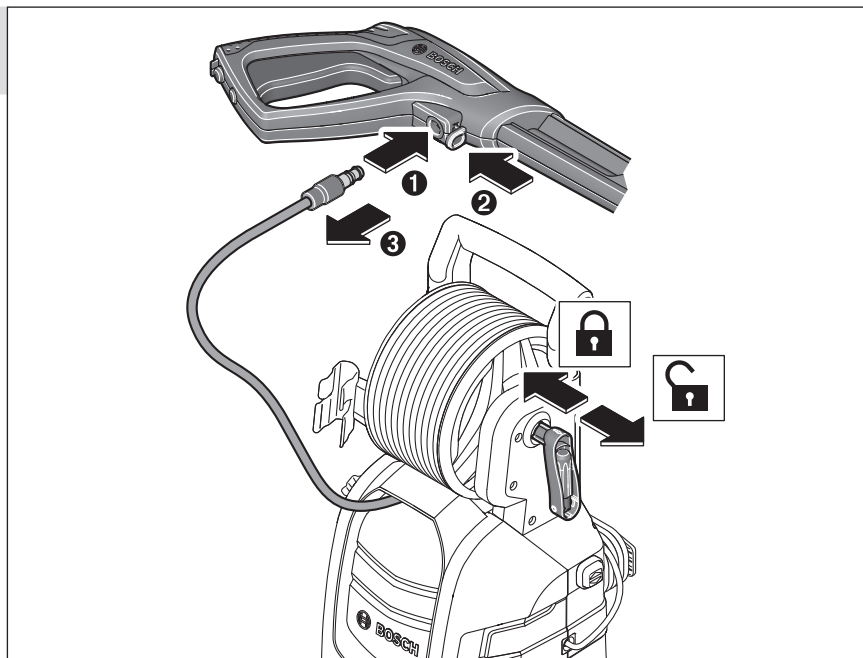

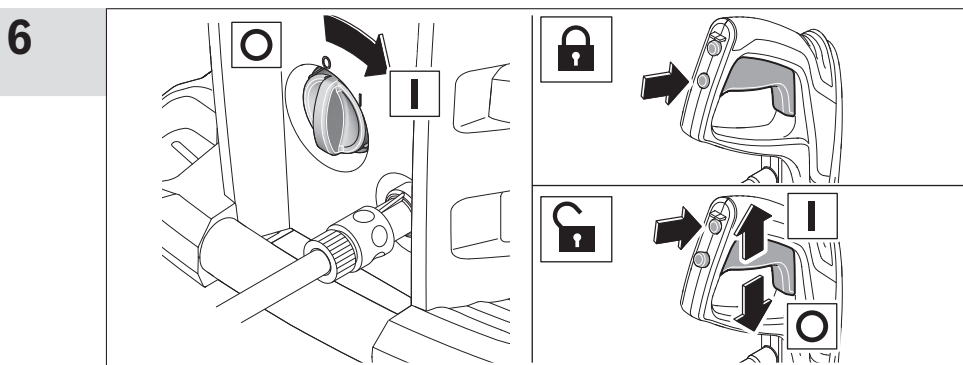
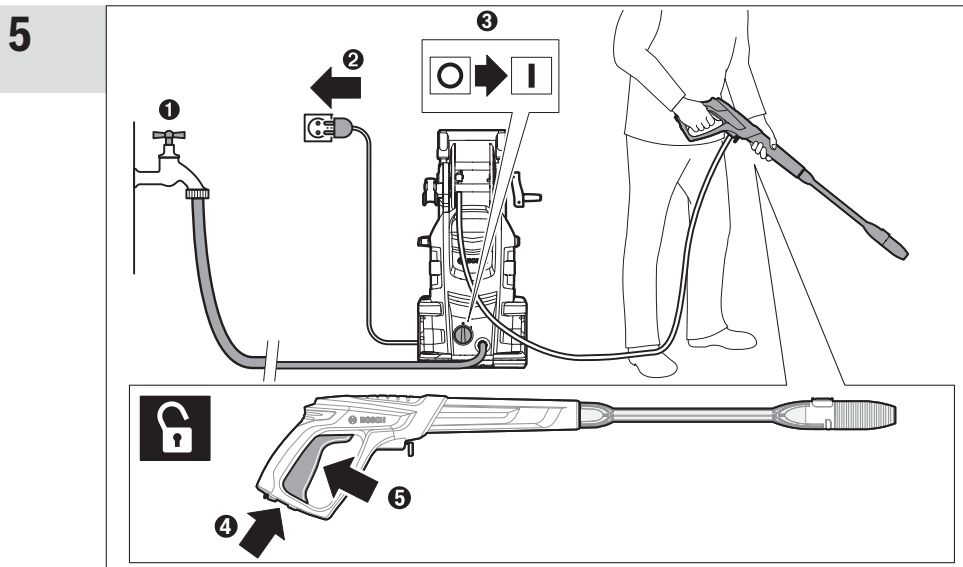
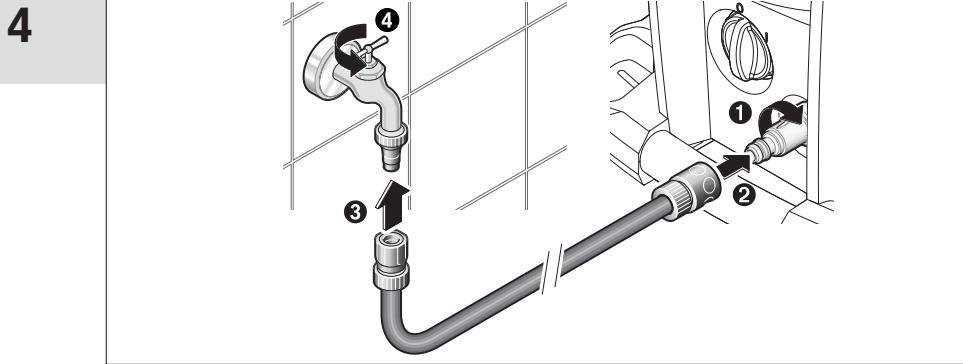

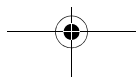
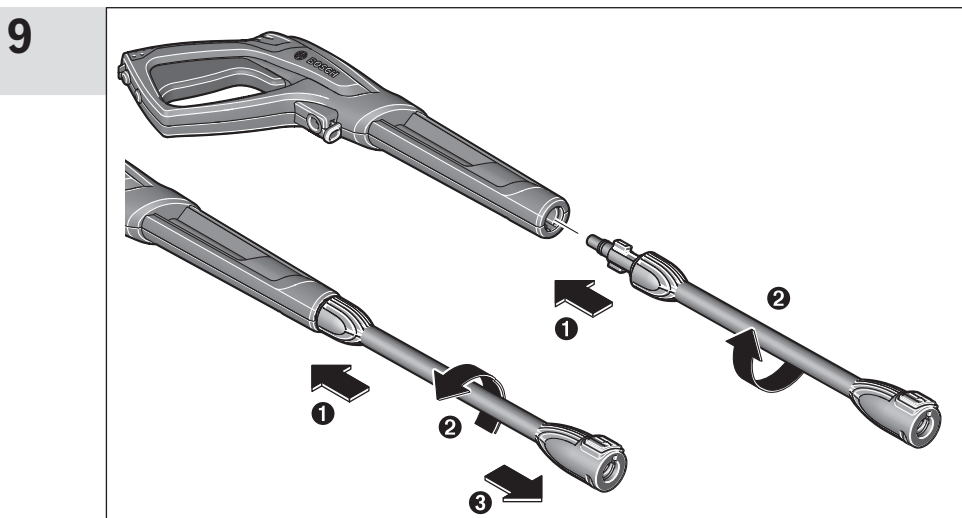
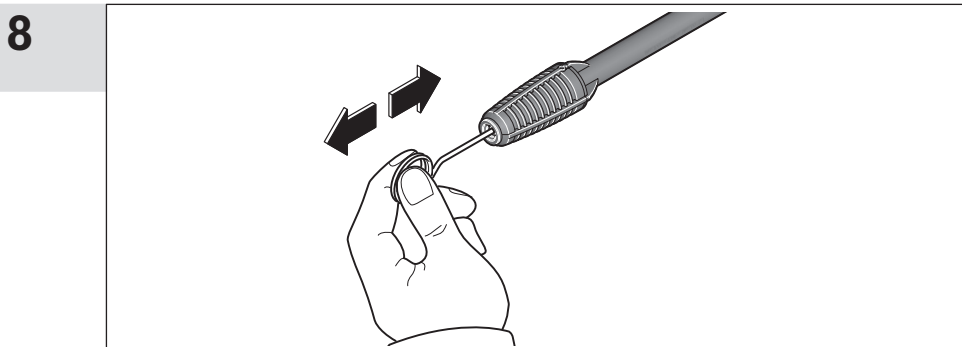
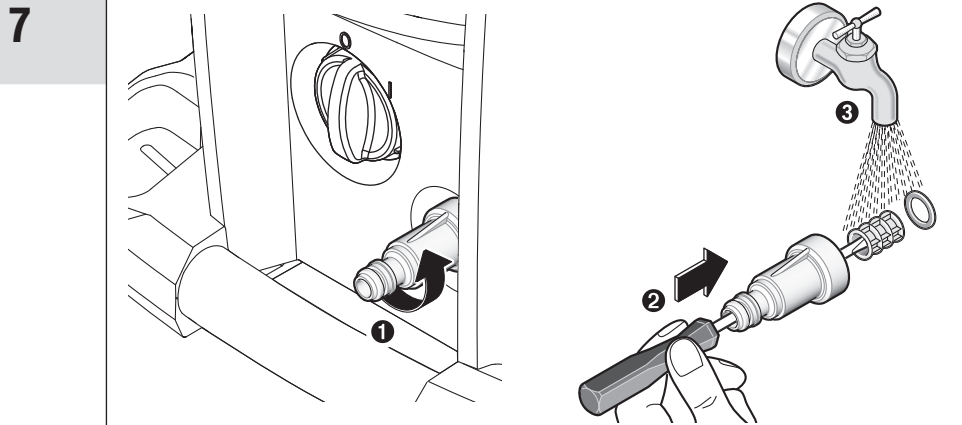

10

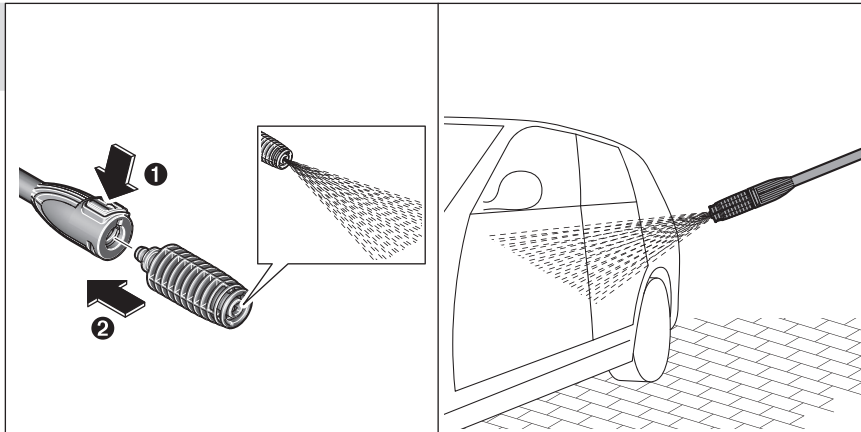

11

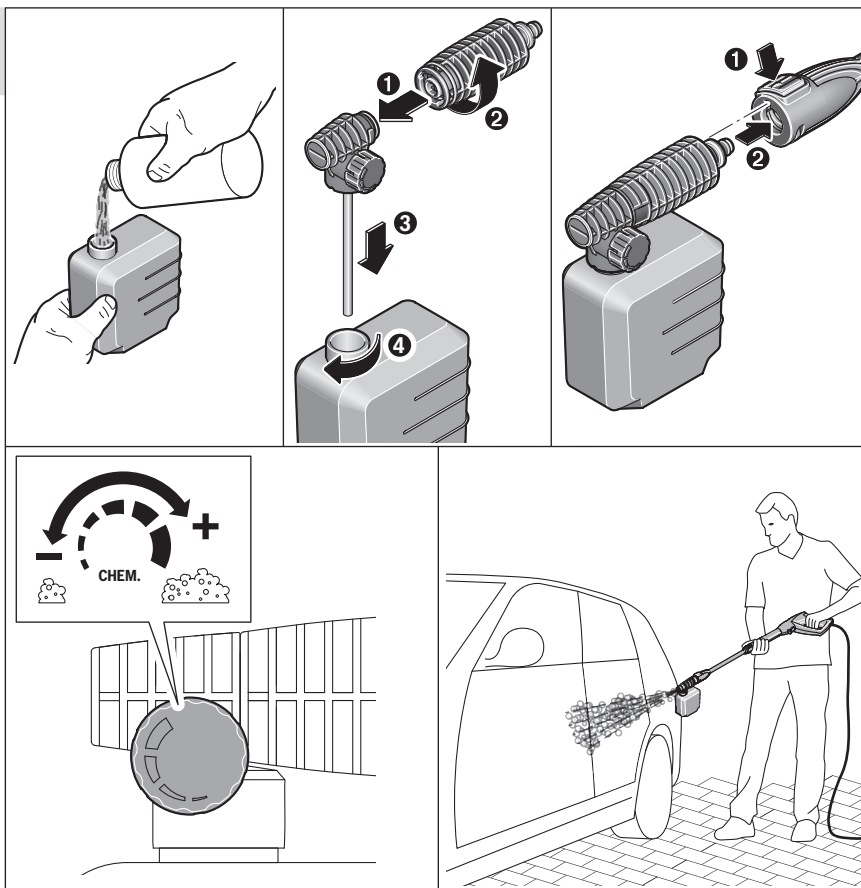

12

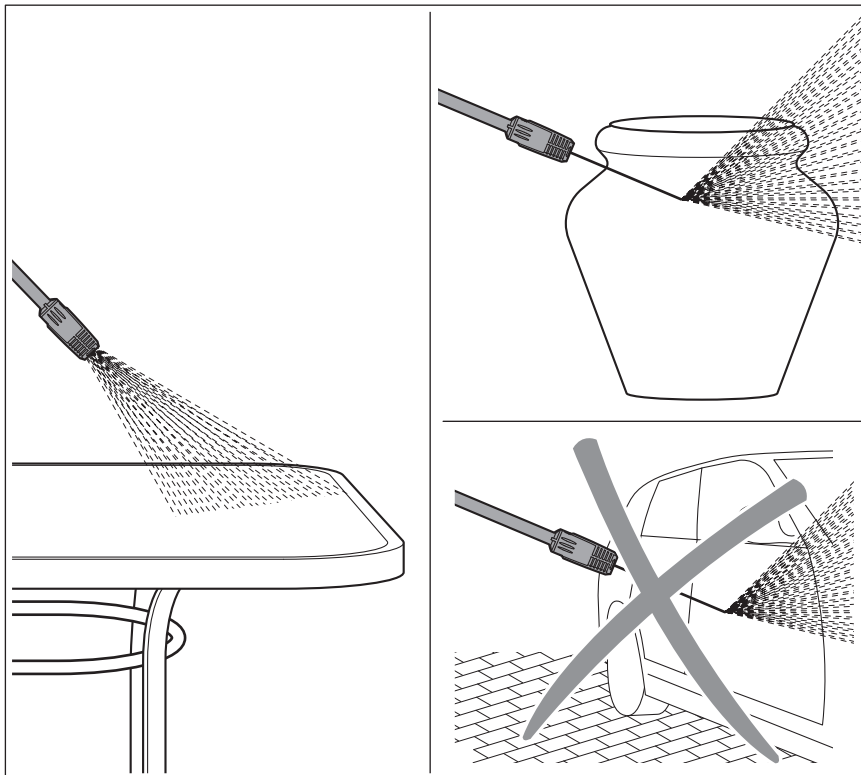
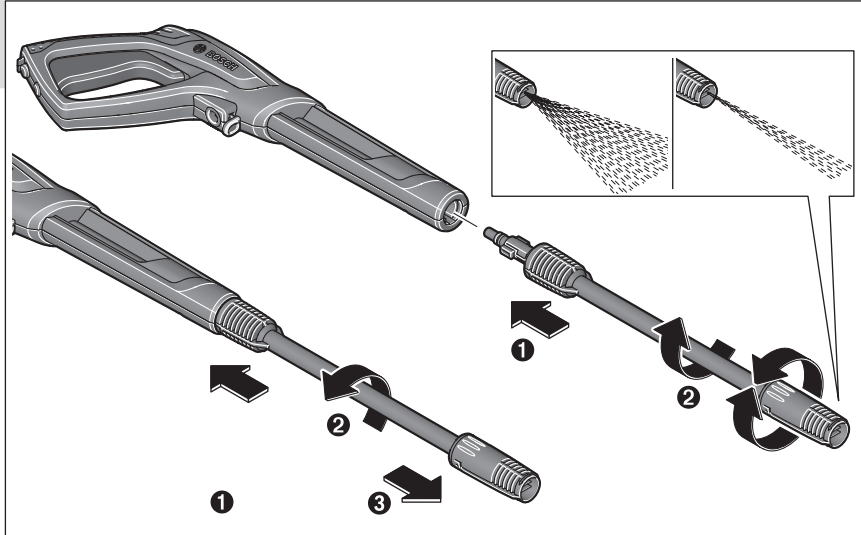



13

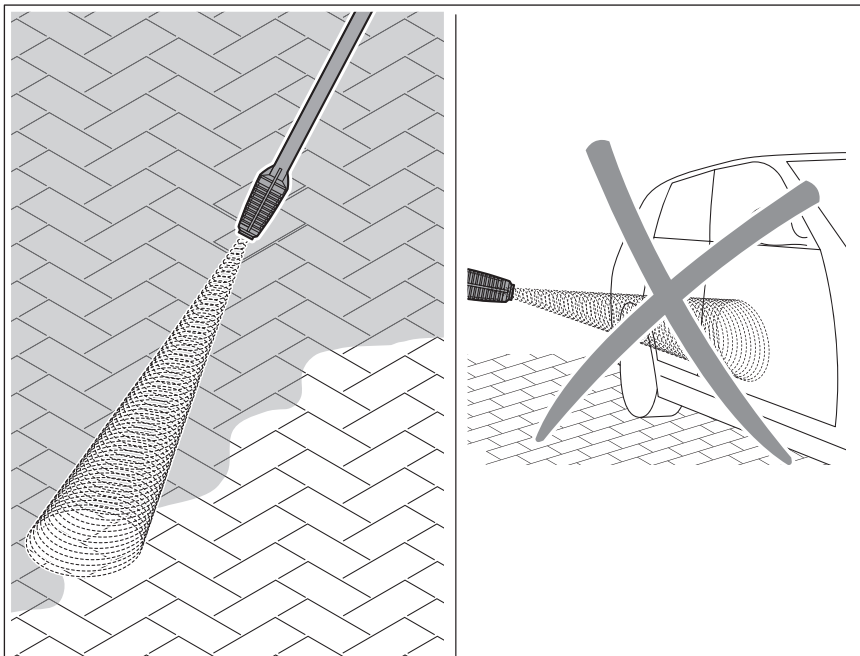
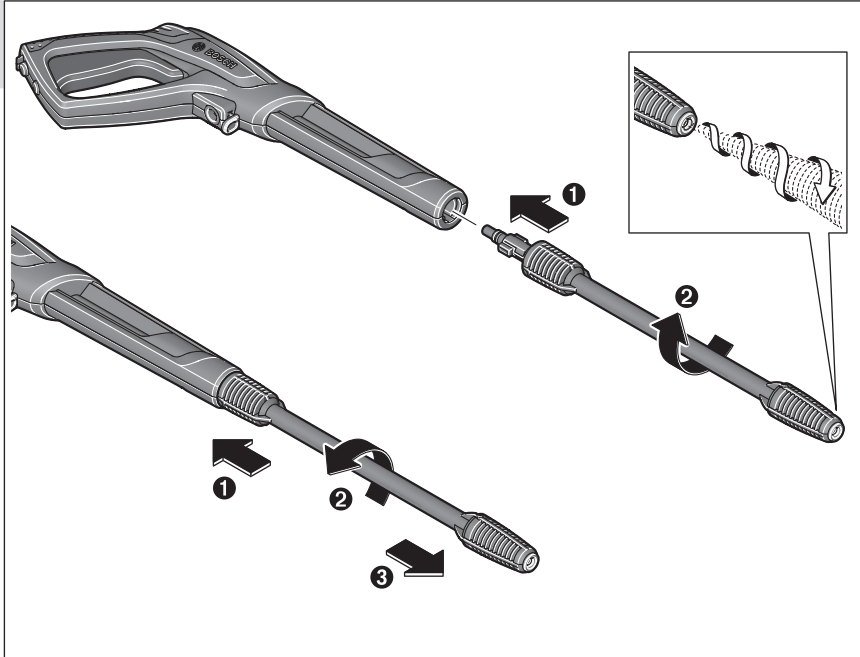



14

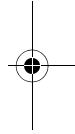
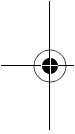
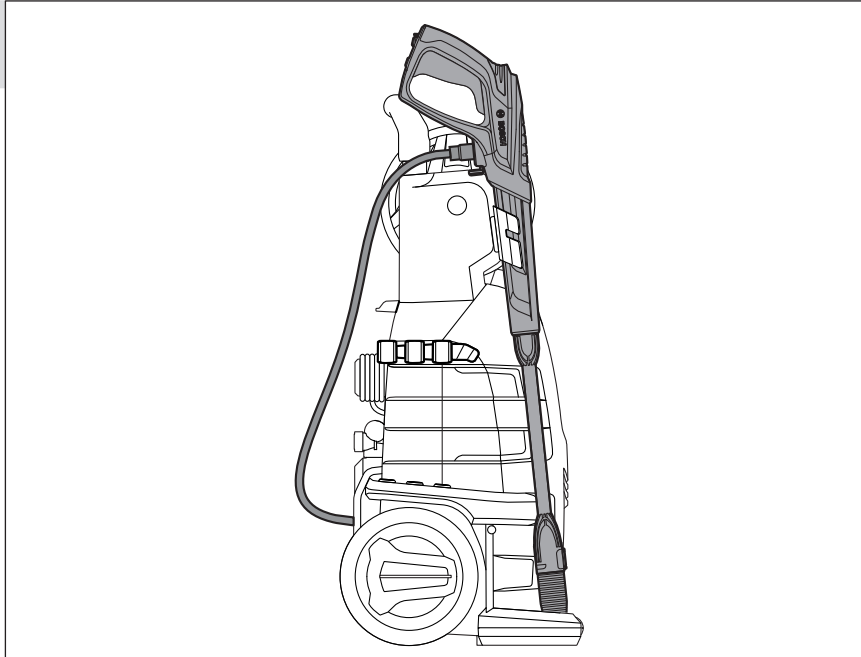

15

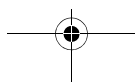
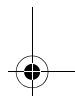
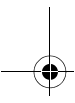
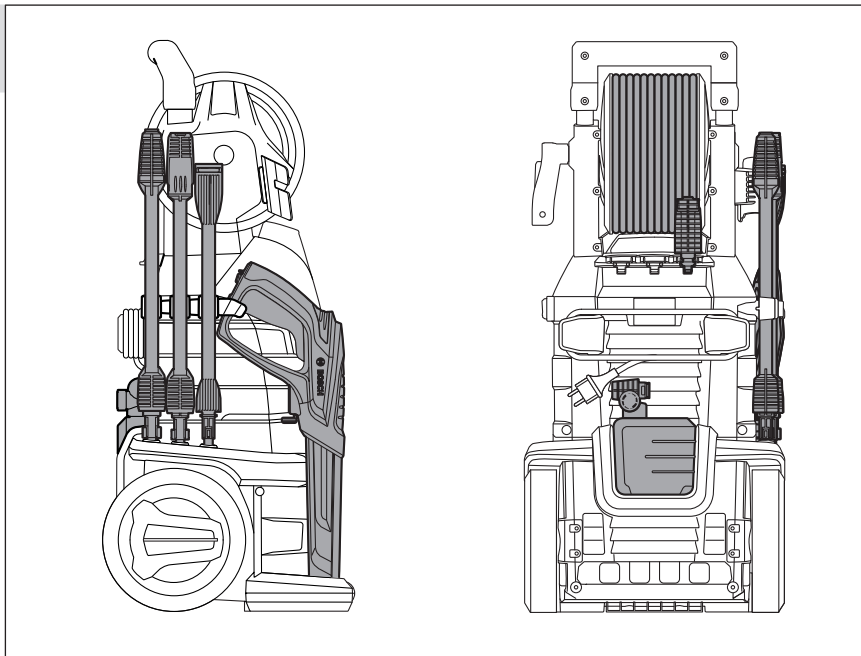



16

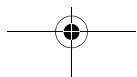
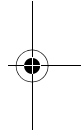
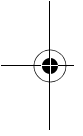
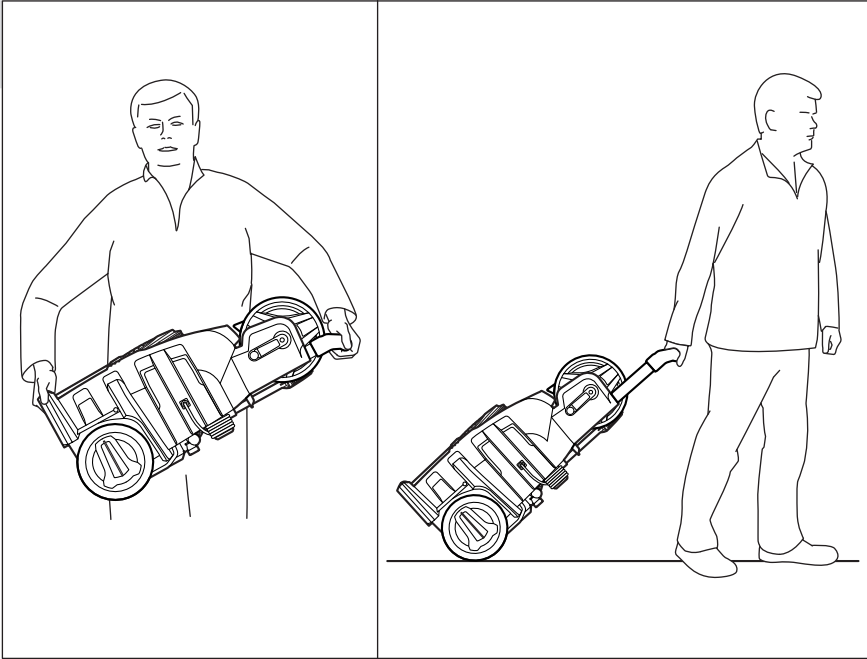

17

